

PRODUCT PORTFOLIO

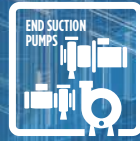
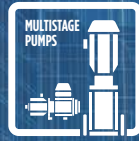

INDEX

PRODUCT PORTFOLIO AND BRANDS 4

COMPANY PROFILE 6

4"/6"/8"/10"/12" SUBMERSIBLE MOTORS 8

4" motors 9

4" Encapsulated motor - 1 Phase, PSC motor 10

4" Encapsulated motor - 1 Phase, 2-wire 10

4" Encapsulated motor - 1 Phase, 3-wire 10

4" Encapsulated motor - 3 Phase 10

4" Encapsulated motor - 3 Phase, High Thrust 10

4" Encapsulated permanent magnet motor 11

4" NBS4 Rewindable oil-filled motor 11

6" motors 12

6" Encapsulated Standard motor 12

6" 3- Encapsulated High Temp 90 °C motor 13

6" 3- Encapsulated permanent magnet motor 13

6" Rewindable motor 14

6" Rewindable Standard motor 14

6" NBS6 Rewindable oil-filled motor 15

8" motors 16

8" Encapsulated Standard motor 16

8" 3- Encapsulated High Temp 75 °C motor 16

8" Rewindable Standard motor 17

8" Rewindable permanent magnet motor 18

10" motors 19

10" Rewindable Standard motor 19

10" Rewindable permanent magnet motor 20

12" motors 21

12" Rewindable Standard motor 21

SUBMERSIBLE BOREHOLE PUMPS 22

VS4 Submersible pump 23

VS6 Submersible pump 23

VS8 Submersible pump 24

VSI 8-10 Submersible pump 24

CLOSE-COUPLED 5" PUMPS 25

ES Submersible pump 26

VN Submersible pump 26

VL Multistage pump 26

4"/6"/8"/10" HIGH EFFICIENCY BOREHOLE SYSTEMS 27

4" High Efficiency System CT 28

4" High Efficiency Solar System CT 28

6" CT High Efficiency System 29

6" CT High Efficiency Solar System 29

8" REW High Efficiency System 30

8" REW High Efficiency Solar System 30

10" High Efficiency System REW 31

10" REW High Efficiency Solar System 31

VERTICAL MULTISTAGE CENTRIFUGAL PUMPS 32

EV Series - Vertical Multistage pumps 33

EM Series - Vertical Close-coupled Multistage pumps 34



BOOSTING SYSTEMS	35
GP Series.....	35
GD Series	35
HORIZONTAL MULTISTAGE PUMPS.....	36
EH Series - Horizontal Multistage pumps	37
EH DTm Series - Horizontal Multistage with DrivE-Tech MINI	38
WASTEWATER & DRAINAGE PUMPS	39
EGN Drainage pump.....	39
ED - EDV Drainage pump.....	39
EGT - EGF Drainage pump.....	40
FWS-FWC Series - Wastewater lift pumps 50 Hz	41
FGR Series - Pumps with grinder unit 50 Hz.....	42
FLV Series - D.C. motor submersible waste water lift pumps 50 Hz	42
FDR Series - Submersible pumps for residential drainage 50 Hz.....	43
FDP Series - Submersible pumps for professional drainage 50 Hz.....	43
5-MSP Utility pump	44
END-SUCTION CENTRIFUGAL PUMPS	45
FNE - Bare Shaft pumps	45
FNC - Extended Shaft pumps.....	46
FNS - Stub Shaft pumps	46
CONSTANT PRESSURE SYSTEM.....	47
VARIABLE FREQUENCY DRIVES (VFD)	48
DrivE-Tech	48
CERUS X-DRIVE.....	48
DrivE-Tech MINI	49
DrivE-Tech MINI Solar	49
DrivE-Tech COMPACT.....	49
PROTECTION / CONTROL	50
SubMonitor Motor Protection.....	50
SubStart SC	50
SubStart 3P	50
Subtronic SC.....	51
Subtronic 3P.....	51
Press-Tech / Press-Tech S	51
COV-BOX M Series.....	52
QC-AV/E Series.....	52
QC-AV Series.....	52
COV-BOX T Series.....	52
ACCESSORIES.....	53
Corrosion Protection 4"	53
Cooling sleeve for submersible motor pumps 4"/6"/8"/10"/12"	53
Motor/Pump-Couplings	53
DC Disconnect.....	53
DrivE-Tech MINI accessory kit	54
Double plug lead for 4" Termination kit.....	54
Motor filling liquid.....	54
Float Switch.....	54
Flow Paddle Switch.....	55
Inline Flow Switch	55
Motor Filling tool kit.....	55
Permanent Star Plug 6"	55
Pressure Switch SubDrive - Constant-pressure Controller.....	55
PT100 sensor for encapsulated motors (Standard / PM)	56
PT100 sensor for rewindable motors.....	56
Pump connection screw kits	56
Splicing Kit 1.5 - 95 mm ²	57
Surge Arrestors.....	57
Termination Kit for 4" motors	57

MOVING WATER IS OUR BUSINESS

MULTISTAGE PUMPS 



EV up to 115 m ³ /h, 326 m	EM up to 17 m ³ /h, 104 m	EH - EH DTm up to 29 m ³ /h, 104 m	VL up to 14 m ³ /h, 104 m	BOOSTER SYSTEMS up to 84 m ³ /h, 104 m
---	--	---	--	---

END SUCTION PUMPS 



FNC - FNS - FNE
up to 240 m³/h, 100 m

DRAINAGE PUMPS 



ED - EDV - EGT - EGF
FWS - FWC - FGR - FLV - FDR - FDP
up to 252 m³/h, 62 m

HIGH EFFICIENCY SYSTEMS 



4"/6"/8"/10" HIGH EFFICIENCY SYSTEM
up to 250 kW

SUBMERSIBLE PRODUCTS 

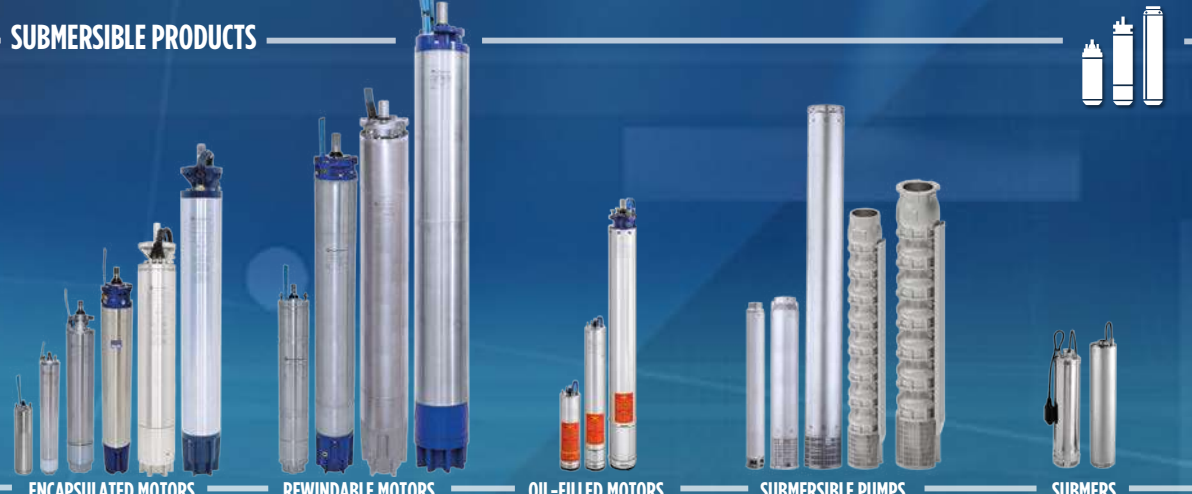

ENCAPSULATED MOTORS 4"/6"/8" up to 150 kW	REWINDABLE MOTORS 6"/8"/10"/12" up to 400 kW	OIL-FILLED MOTORS 4"/6" up to 30 kW	SUBMERSIBLE PUMPS 4"/6"/8"/10" up to 350 m ³ /h	SUBMERS. MULTISTAGE PUMPS up to 14 m ³ /h, 104 m
---	--	---	--	---

OUR PRODUCT PORTFOLIO – OUR BRANDS

Franklin Electric offers high-quality pumping systems for submersible well and surface applications.

COMPLETE SYSTEMS PROVIDER

The submersible pumping systems consist of perfectly matching components from motors and pumps to drives and controls to enhance efficiency, security and lifetime. The portfolio of **submersible motors** includes encapsulated and rewindable motors in the range from 0.25 kW up to 400 kW. While Franklin offers a full line of 4-inch motors for single and three-phase voltages and various frequencies, the product line ranges up to large submersible motor sizes up to 12" and 3300 V.

Under the brand name E-Tech, there is a wide range of **submersible pumps** from 4 inch up to 10 inch including close-coupled 5 inch pumps. Moreover, there are vertical and **horizontal Multistage pumps** with cutting edge technology in terms of performance and efficiency. The portfolio is completed with the range of **pressure boosting systems, small drainage and end suction pumps**.

The Coverco brand produces 4-inch and 6-inch **oil-filled rewindable motors** which are recognized in the market for their robustness and reliability. They are available from 0.37 up to 30 kW as single and three phase versions.

Besides the motor and pump portfolio, Franklin Electric has developed innovative products such as the constant-pressure system SubDrive Connect or various controls for submersible and surface pumping systems.

In consideration of environmental relief and energy saving Franklin Electric offers the **High Efficiency System (HES)** with first-class performance and power ratings up to 250 kW, increased lifetime and energy savings up to 21 %. Diverse Solar Pumping Systems enable the operation without electricity supply such as the 4"-10" Solar High Efficiency Systems.



Franklin Electric

FPS

E-Tech®

COVERCO®

HYDROPOMPE

Little GIANT®

OUR MARKETS

Agriculture: Relying on Mother Nature to irrigate crops, irrigate pastures or provide drinking water for animals is risky, especially when unpredictable drought periods hit the hardest. Franklin's agriculture pumping system provide stability to increase output, better predict crop yields and keep your animals strong and hydrated.

Commercial: At the turn of a faucet or flip of a lever, customers count on your commercial building to supply water at the pressures that serve their needs, whether the building is 1 story or 100. Franklin's complete line of pumping systems eliminate the worry and customer headaches that result from failed pumping equipment and help you overcome the challenge of supplying proper water pressure at varying structure heights.

Residential: Homeowners expect the tap to flow when they request water for any reason. So, whether your customers need water for general household use, desire lawn irrigation or want to boost their water pressure, our pumping systems provide the reliability you expect to minimize service calls and maximize customer satisfaction.

Industrial: To maximize production of your niche output, equipment cooling and washing systems along with general water usage systems are expected to run at peak efficiency for long durations. Franklin products not only transfer the water needed to maintain these efficiencies, but they provide protection to extend the life of your pumping system and ultimately the value of your industrial operation.

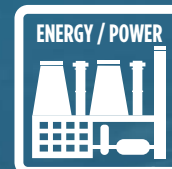

FRANKLIN ELECTRIC – MOVING WATER. MOVING FORWARD.

OUR VISION

Franklin Electric has grown from a small motor manufacturing company into a leading global provider of systems and components for moving water and fuel.

Named after America’s pioneer electrical engineer, Benjamin Franklin, we continue to follow the core of our founders’ strategy by continuously improving our products and processes to deliver valuable and innovative solutions that better serve our customers’ needs.

Recognized as a technical leader in its products and services, Franklin serves customers around the world in residential, commercial, agricultural, industrial and municipal, and fueling applications.

Health, Safety, and the Environment

We touch the lives of millions of end-users of our products. We thoughtfully consider and continuously recognize the impact we make on the people of these communities and on the environment.

Our vision is to be an indispensable partner to our customers by consistently delivering products of the highest quality available in the market, providing training that reflects the importance of the safety of our customers and end-users and that protects the environment, and developing innovative products that deliver unparalleled performance and support sustainable energy sources. Our goal is to accomplish these objectives in ways that deliver value to our customers and shareholders.

Clean and readily available groundwater is vital to the health and well-being of much of the world’s population, and the success of our water systems business is inextricably linked to this necessity. Pollution of groundwater aquifers represents a clear danger to human health and the environment. We therefore do our part, by lowering our own environmental impact by mandating clean, sustainable manufacturing and distribution processes, and by designing products that themselves protect against environmental damage.

Headquartered in Fort Wayne (Indiana/USA), Franklin employs 5,000 people globally, is present in over 50 worldwide locations and generates a sales turnover of 1.15 billion Euro.

Franklin Electric is committed to providing high quality products and services to our customers. Through our Franklin Leadership System, we are focused on a culture of continuous improvement to ensure we offer the best value to our customers.

Franklin Wells for the World Foundation

There are nearly one billion people in the world that don’t have access to safe, clean drinking water. For most of us, a drink of fresh, clean water is only a few feet away. However, in many developing regions the nearest source of water is a few miles, and the only water they have is, in most cases, contaminated. These unclean water sources cause cholera, diarrhea, dehydration, dysentery, and in many cases, death. In one week, approximately 47,000 people die from a water-related disease; 90% of those deaths are children under five. That’s approximately 6,000 children every day or one child every 15 seconds.

A majority of the world’s fresh water is buried hundreds of feet below the ground, and Franklin Electric is the world leader in accessing groundwater. Since the inception of Franklin Wells for the World Foundation in 2010, we’ve impacted the lives of over 160,000 people by bringing this water to the surface.

Our mission is to provide safe, reliable, and cost-effective water supplies to suffering communities, focusing on Africa, where the need is greatest. It is our goal to provide fundraising and technical resources for water projects, as well as provide global partnerships for charitable organizations. Franklin Wells for the World is our effort and commitment to help end the global water crisis.



OUR VALUES

Focusing on a culture of continuous improvement, driven by our Key Factors for Success, we strive to be a leading provider of quality water and fueling systems, and will continue to expand our influence, while making a difference in the world.

QUALITY: The components and products are developed and manufactured according to the highest industry quality standards. In the state-of-the-art production and laboratory facilities, all products are tested to 100% to ensure maximum quality.

INNOVATION: Franklin Electric's commitment to innovation means that we evaluate and incorporate new technologies into our existing products, services and processes to continuously improve value to our customers. Franklin does not search for avant-garde technologies purely for the sake of change, but instead embraces innovations and solid solutions that make a sustainable difference.

SERVICE: Franklin Electric supports its customers beyond the commissioning of the system. The industry's leading problem-solving Technical Service Hotline professionals and Expert Field Service Engineers provide real answers in real time for troubleshooting and/or product questions. We are passionate about providing industry-leading technical service, robust training programs, and unwavering support and communication.

AVAILABILITY: We are committed to delivering our products and services when and where our customer needs them.

COST: We consider cost in every decision we make. We strive to control cost for the benefit of all our stakeholders.





4"/6"/8"/10"/12" SUBMERSIBLE MOTORS

Named after Benjamin Franklin, a pioneer in electrical engineering, Franklin Electric's core is the world's first reliable submersible electric motor for water systems, which has remained a staple of the water well industry.

More than 75 years after the establishment of Franklin Electric, we continue to manufacture and distribute improved versions of this unrivaled motor design all around the world, and have expanded our expertise to create innovative solutions, including pumps, electronics, and adjacent products, addressing modern industry challenges and serving our customers' needs.

Drinking water approvals (Franklin Electric Motoren)



SandFighter® sealing system

with SiC/SiC mechanical seal and sand slinger (6-12")



ISO 9001

All products are manufactured in ISO 9001 certified plants and 100% tested



StatorShield™ - Franklin encapsulation system

Franklin Electric encapsulated motors are equipped with hermetically-sealed windings. The stator resin mechanically supports the winding and provides fast heat dissipation.

Hydrodynamic liquid lubricated radial bearings

100% maintenance free operation for all Franklin Electric encapsulated and rewindable motors
Oil-filled motors are equipped with ball bearings.

Kingsbury type thrust bearing

High capacity Kingsbury type thrust bearing for 100 % maintenance free operation for all Franklin Electric encapsulated and rewindable motors.



Pressure-equalizing diaphragm

NEMA mounting design

Standard NEMA dimensions for all products 4" - 8"

Best class winding wires in rewindable motors

The rewindable motors are equipped with best class winding wires.
The windings can easily be replaced.

The Franklin motors are factory filled with Franklin's FES non-toxic water soluble fill solution.
The Coverco motors are filled with dielectric fluid (known as ›white oil‹), approved by the FDA.



4" SUPER STAINLESS ENCAPSULATED MOTOR

High-quality encapsulated motor with hermetically-sealed windings



FEATURES & BENEFITS

- 4" NEMA mounting design with studs
- Cable with round plug with extended jam nut (for better handling) in the conventional proven design
- Stator with solid 304SS end ring for better corrosion resistance and robustness
- Stainless steel splined shaft
- Stator shell in 316SS
- Factory filled with Franklin's FES93 motor fill solution
- Liquid lubricated radial bearings and High capacity Kingsbury type thrust bearing for 100 % maintenance free operation
- Field replaceable lead using Franklin's exclusive Water Bloc technology
- Pressure-equalizing diaphragm
- High efficiency electrical design for low operation costs
- Drinking water approvals
- Suitable for use in water with increased salinity 

OPTIONS

- Built in lightning arrestors
- Special lead length up to 50 m
- Higher-graded materials: 316SS (only 3-wire and 3-phase motors)
- PSC Motor kits (motor, motor short lead, control box, lead splicing kit)
- Permanent magnet technology

Pollution Recovery version:

- Fluorelastomere (Viton®) rubber parts
- Special Polyuretane (PUR) lead assemblies
- 304SS (316SS Stator) graded Stainless Steel as Standard

STANDARD SPECIFICATION

- Electrical Designs: 1 - PSC / 2-wire 1- / 3-wire 1- / 3-
- Thrust load: 4 kN / 6.5 kN
- Nominal ambient temperature: 30 °C with 0.08 m/s cooling flow
- Voltage tolerance U_n : -10 % / +6 % (50 Hz), ±10 % (60 Hz)
- Protection IP68 and insulation class B
- Frequency of starts: 20 starts/ hour (with min. 3 minutes resting time), equally distributed
- Vertical and horizontal operation, shaftend heightend
- Rotation counter clock wise facing shaft end (1 phase motors CW upon request; 3 phase motors rotation reversible)
- All motors with factory installed leads (1.50 m / 2.50 m)



Heat Pump motor version (3 phase version only):

Many modern heating systems extract heat that is stored in aquifer / river water. Such so-called two-pit or open systems require low-power, high efficiency 3-phase submersible motors. To meet the demands of this niche market, Franklin Electric has developed a special 4" encapsulated submersible motor range optimized for shallow settings and low power consumption available from 0.25 kW to 1.1 kW.

Watch the Youtube videos:



overview 4" encapsulated motors



lead installation of 4" encapsulated motors



High Efficiency System with 4" permanent magnet motor

4" SUPER STAINLESS ENCAPSULATED MOTOR

4" ENCAPSULATED MOTOR - 1 PHASE, PSC MOTOR

- Ratings: 0.25 - 2.2 kW; Thrust load 4 kN
- Single phase motor for operation with external run capacitor
- Electrically optimized to offer reliable pump starting over a wide range of incoming voltages.
- Max. storage temperature -15°C - + 50°C
- Optimized performance and protection with Franklin SubStart/ SubTronic control boxes
- Protection requirements: EN 60947-4-1



4" ENCAPSULATED MOTOR - 1 PHASE, 2-WIRE

- Ratings: 0.37 - 1.1 kW; Thrust load 4 kN
- Integrated start components for the operation without external controls or capacitors, minimal installation work
- Reverse impact torque for loosening sand-locked pumps
- Factory-equipped with automatic reset overload and surge protectors, no start-up device required
- Max. storage temperature -15°C - + 50°C
- Integrated lightning arrester (max. 230 V) and overload
- Electrically optimized to offer reliable pump starting over a wide range of incoming voltages
- Protection requirements: EN 60947-4-1



4" ENCAPSULATED MOTOR - 1 PHASE, 3-WIRE

- Ratings: 0.25 - 2.2 kW; Thrust load 4 kN
High Thrust version: 2.2 - 3.7 kW, Thrust Load: 6.5 kN
- Single phase motor with highest achievable starting torque for operation with external start & run capacitor
- Ideally suited for applications where starting torque is paramount and 3 phase motors can not be used.
- Max. storage temperature -15°C - + 50°C
- Ideally combined to the Franklin Electric 3-wire control boxes for maximum system performance, protection and warranty.
- Protection requirements: EN 61947-4-1
- Optionally: motor complete in 316SS with SiC seal



4" ENCAPSULATED MOTOR - 3 PHASE

- Ratings: 0.37 - 3.0 kW; Thrust load 4 kN
- Three phase motor with highest efficiency and maximum product life under various load conditions
- Optimized performance and protection with Franklin SubStart 3P / SubTronic 3P control boxes
- Protection requirements: EN 60947-4-1
- Optional: motor complete in 316SS with SiC seal, Special voltages
- Max. storage temperature -15°C - + 50°C

Solar Version:

- Optimized design for use with solar panels
- Ratings: 0.75 - 1.1 kW
- Optimized performance with Franklin DrivE-Tech MINI

Heat pump motor

- Optimised design for operation in heating systems that extract heat from groundwater and river water (deep heat wells or open systems)
- Power: 160 - 1100 Watt



4" ENCAPSULATED MOTOR - 3 PHASE, HIGH THRUST

- Ratings: 2.2 - 9.3 kW, Thrust load: 6.5 kN
- Three phase motor with highest efficiency and maximum product life under various load conditions
- Optimized performance and protection with Franklin SubStart 3P / SubTronic 3P control boxes
- Optionally: motor complete in 316SS with SiC seal, Special voltages
- Max. storage temperature -15 °C - + 50 °C
- Protection requirements: EN 60947-4-1
- Pressure-equalizing diaphragm, spring pre-loaded



4" SUPER STAINLESS ENCAPSULATED MOTOR

4" ENCAPSULATED PERMANENT MAGNET MOTOR

- NEMA mounting design
- Stainless steel splined shaft
- StatorShield™ - Franklin encapsulation system
- Factory filled with Franklin's FES93 motor fill solution
- Max. storage temperature 0°C - + 50°C
- Liquid lubricated radial bearings and High capacity Kingsbury type thrust bearing for 100 % maintenance free operation
- Field replaceable lead using Franklin's exclusive Water Bloc technology
- Pressure-equalizing diaphragm
- Protection IP68 and insulation class B
- Frequency of starts: 20 starts/ hour (with min. 3 minutes resting time), equally distributed
- All motors with factory installed leads 1.50 / 2.50 m
- Vertical and horizontal operation, shaftend heightend

- Ratings:
0.55 - 3.0 kW; Thrust load 4 kN
3.0 - 7.5 kW; Thrust load 6.5 kN
- Voltage: 220/380 V (100/120 Hz)
- Voltage tolerance U_N : ± 10 %
- Nominal ambient temperature:
30 °C with 0.08 m/s cooling flow



OPTIONS



- High Efficiency System Package
 - Synchronous 4" NEMA motor
 - Submersible pump
 - Variable Frequency Drive
 - Matching output filter
- ▶ 4" High Efficiency System



4" REWINDABLE OIL-FILLED MOTOR

4" NBS4 REWINDABLE OIL-FILLED MOTOR

Rewindable oil-filled submersible motors

FEATURES & BENEFITS

- NEMA mounting design
- Stainless steel splined shaft
- Motors are pre-filled with a dielectric fluid (known as „white oil“), approved by the FDA and other international pharmacological institutes
- The motors can be powered with single-phase and three-phase power supply.
- Cable material compliant with drinking water standards
- Reliable operation in wells with diameters of ≥ 4" for water up to 30 °C
- Axial and radial oil lubricated bearings allow maintenance-free operation
- Pressure compensation inside the motor is ensured by a special membrane
- Sand protection / Mechanical seal allow optimal operation even in the presence of sand in the well
- Excellent efficiency and low operating costs
- Standard motor cable lengths: 0.37-2.2 kW: 1.50 m; 3.0-5.5 kW: 2.50 m; 7.5 kW: 3.50 m

STANDARD SPECIFICATION

- Motor ratings: Single-phase: 0.37 - 4.0 kW, Three-phase: 0.37 - 7.5 kW
- Standard rated voltage:
Single-phase: 210-220-230 V (50 Hz),
Three-phase: 380-415 V (50 Hz); 460 V (60 Hz)
- Nominal ambient temperature:
30 °C with 0.08 m/s cooling flow
- Voltage tolerance U_N : ±10 %
- Protection IP68, Insulation class F
- Motor protection: thermal relays in compliance with EN 60947-4-1, trip class 10 or 10 A, trip time < 10 s. at $5 \times I_N$
- Frequency of starts: 30 starts/ hour
- Thrust load: 1500 N, 2500 N, 4500 N (K)
- Vertical and horizontal operation (for horizontal operation authorization by Franklin Electric Technical Department necessary)
- Cable dimensions: 4 x 1.5 mm²



OPTIONS

- Special Voltages
- Silicon carbide mechanical seal



6" ENCAPSULATED MOTOR

High-quality encapsulated motor with hermetically-sealed windings



6" ENCAPSULATED STANDARD MOTOR

FEATURES & BENEFITS

- Double-flange NEMA mounting design
- Stainless steel splined shaft
- StatorShield™ - Franklin encapsulation system
- Factory filled with Franklin's FES91 motor fill solution
- Liquid lubricated radial bearings and High capacity Kingsbury type thrust bearing for 100 % maintenance free operation
- Field replaceable lead using Franklin's exclusive Water Bloc technology
- Pressure-equalizing diaphragm, spring pre-loaded
- Standard motors WW (Water well)- Stator 304SS / Castings - CI Powder coated
- SandFighter™ sealing system with SiC/SiC mechanical seal and sand slinger
- High efficiency electrical design for low operation costs
- Drinking water approvals

STANDARD SPECIFICATION

- Ratings: 4 - 45 kW
- Thrust load: 15.5 kN: 4 - 22 kW, 27.5 kN: 30 kW, 45 kN: 37 - 45 kW
- Max. storage temperature - 15 °C - +60 °C
- Nominal ambient temperature (with 0.16 m/s cooling flow): 4 - 30 kW: 30 °C, 37 - 45 kW: 50 °C
- Standard Voltage: 50 Hz: 380-415 V -10 % / +6 % UN [380-415 V = (380-10%) - (415+6 %)]; 60 Hz: 460V / ± 10 % UN
- Protection IP68, Insulation class F
- Motor protection: DIN 61947-4-1
- Frequency of starts: 20 starts/ hour (with min. 3 minutes resting time), equally distributed
- DOL / YΔ - start (pos. of cables 90 °)
- Motor lead length: 4 m
- Vertical and horizontal operation, shaftend heightend
- Rotation counter clock wise facing shaft end (Rotation reversible for 3 phase motors)
- Integrated SubMonitor™ sensor (37 and 45 kW)

OPTIONS

- Higher-graded material: 304SS, 316SS
- Special Voltages
- 45 kN High Thrust version (Standard in 37 kW and 45 kW)
- Retrofittable PT 100 temperature sensor
- Integrated SubMonitor™ sensor (Standard for 37 and 45 kW)
- Special lead lengths up to 50 m



6" ENCAPSULATED MOTOR

High-quality encapsulated motor with hermetically-sealed windings

6" 3~ ENCAPSULATED HIGH TEMP 90 °C MOTOR

Encapsulated motor for reliable operation with ambient temperatures up to 90 °C

- HighTemp 90 °C version for reliable operation with ambient temperatures up to 90 °C (with 0.16 m/s cooling flow)
- Ratings: 3.7 - 30 kW
- Liquid lubricated radial bearings and High capacity Kingsbury type thrust bearing for 100 % maintenance free operation
- SandFighter™ sealing system with SiC/SiC mechanical seal and sand slinger
- Increased thrust capacity up to 30 °C
- Factory filled with Franklin's FES92 motor fill solution
- Standard motors WW (Water well) - Stator: 304SS / Castings - CI Powder coated
- No cooling flow in larger wells necessary (12" / open reservoirs) up to 30 °C ambient temperature
- DOL / YΔ - start (pos. of cables 90 °)



- Vertical and horizontal operation, shaftend heightend
- High temperature leads
- All features of the Standard version
 - ▶ Standard 6" Encapsulated motor

OPTIONS

- Special Voltages
- Higher-graded material: 316SS
- 45 kN High Thrust version (Standard in 22 kW and 30 kW)
- Retrofittable PT 100 temperature sensor
- HighTemp drop cable



6" 3~ ENCAPSULATED PERMANENT MAGNET MOTOR

Synchronous encapsulated motor for first-class efficiency

- Permanent Magnet Technology
- Up to 15 points (21 %) improved motor efficiency*
- Investment payback of less than two years
- Ratings: 4 - 45 kW, 380 V (100 Hz)
- Voltage Tolerance U_N : ±10 %
- Nominal speed: 3000 rpm (100 Hz), 3600 rpm (120 Hz)
- Nominal ambient temperature: 30 °C (≤ 22 kW: with 0.16 m/s cooling flow, ≥ 26 kW: with 0.5 m/s cooling flow)
- Standard motors WW (Water well) - Stator: 304SS / Castings - CI Powder coated
- All features of the Standard version
- Vertical and horizontal operation, shaftend heightend



OPTIONS

- 45 kN High Thrust version
- Higher-graded material: 304SS, 316SS
- Retrofittable PT 100 temperature sensor
- Special lead lengths up to 50 m
- 60 Hz electrical designs
- High Efficiency System package
 - Synchronous subm. NEMA motor
 - Submersible pump
 - Variable frequency drive
 - Matching output filter
- ▶ 6" High Efficiency System



*compared to asynchronous motor technology

6" REWINDABLE MOTOR

Rewindable motors with best class winding wires

OPTIONAL OPTIONAL

STAINLESS STEEL STAINLESS STEEL STAINLESS STEEL

304 **316** **904L**



6" REWINDABLE STANDARD MOTOR

FEATURES & BENEFITS

- 6" NEMA mounting design with studs
- Stainless steel splined shaft
- Factory filled with Franklin's FES93 motor fill solution
- Liquid lubricated radial bearings and High capacity Kingsbury type thrust bearing for 100 % maintenance free operation
- Pressure-equalizing diaphragm, spring pre-loaded
- SandFighter™ sealing system with SiC/SiC mechanical seal and sand slinger
- High efficiency electrical design for low operation costs
- Drinking water approvals

STANDARD SPECIFICATION

- Ratings: 4 - 37 kW
- Max. storage temperature - 15 °C - +60 °C
- Standard motor with PVC winding insulation (37 kW Standard with PE2/PA insulation)
- Nominal ambient temperature: 30 °C with 0.2 m/s cooling flow for 4 - 15 kW motors with 0.5 m/s cooling flow for 18.5 - 37 kW motors
- Standard Voltage: 380 - 415 V (50 Hz), 460 V (60 Hz)
- Voltage Tolerance U_N : 50 Hz: 380-415 V -10 % / + 6 % [380-415 V = (380 - 10%) - (415 + 6 %)]; 60 Hz: 460V / ±10 %
- Protection IP68
- Motor protection: DIN 61947-4-1
- Frequency of starts: 20 starts/ hour (with min. 3 minutes resting time), equally distributed
- DOL / YΔ - start (pos. of cables 90 °)
- Motor lead length: 4 m
- Installation orientation: Vertical / horizontal (shaft end heightened) - 37 kW motors may not be installed in horizontal position)
- Rotation counter clock wise facing shaft end (rotation reversible)
- All motors with factory installed leads

OPTIONS

- Higher-graded material: 316SS, 904L
- Special Voltages
- Retrofittable PT 100 temperature sensor
- Special lead lengths up to 50 m
- Motors up to 30 kW with PE2/PA winding insulation for max. ambient temperature of 50 °C (Standard cooling flows, 37 kW: max. 45 °C)



6" REWINDABLE OIL-FILLED MOTOR

Rewindable oil-filled submersible motors



6" NBS6 REWINDABLE OIL-FILLED MOTOR

FEATURES & BENEFITS

- NEMA mounting design
- Motors are pre-filled with a dielectric fluid (known as „white oil“), approved by the FDA and other international pharmacological institutes
- Cable material compliant with drinking water standards
- Reliable operation in wells with diameters of $\geq 6''$ for water up to 30 °C
- Axial and radial oil lubricated bearings allow maintenance-free operation
- Sand protection / Mechanical seal allow optimal operation even in the presence of sand in the well
- Excellent efficiency and low operating costs

OPTIONS

- Special Voltages
- Silicon carbide mechanical seal
- DOL / $Y\Delta$ - start (pos. of cables 90 °)
- Special lead lengths



STANDARD SPECIFICATION

- Motor ratings: Three-phase: 4.0 - 30.0 kW
- Standard rated voltage: Three-phase: 380-415 V (50 Hz); 460 V (60 Hz)
- Nominal ambient temperature: 30 °C with 0.16 m/s cooling flow
- Voltage Tolerance U_N : $\pm 10\%$
- Protection IP68, Insulation class F
- Motor protection: thermal relays in compliance with EN 60947-4-1, trip class 10 or 10 A, trip time < 10 s. at $5 \times I_N$
- Frequency of starts: 20 starts/ hour
- DOL / $Y\Delta$ - start (pos. of cables 90 °)
- Thrust load: 10.000N, 20.000N
- Vertical and horizontal operation (for horizontal operation up to 11 kW authorization by Franklin Electric Technical Department)
- 4 meter removable cable, cable dimensions: 4 mm² / 8.3 mm²



8" ENCAPSULATED MOTOR

High-quality encapsulated motor with hermetically-sealed windings



8" ENCAPSULATED STANDARD MOTOR

FEATURES & BENEFITS

- Double-flange NEMA mounting design
- Stainless steel splined shaft
- StatorShield™ - Franklin encapsulation system
- Factory filled with Franklin's FES91 motor fill solution
- Liquid lubricated radial bearings and High capacity Kingsbury type 45 kN thrust bearing for 100 % maintenance free operation
- Field replaceable lead using Franklin's exclusive Water Bloc technology
- Pressure-equalizing diaphragm, spring pre-loaded
- Standard motors WW (Water well) - Stator: 304SS / Castings - CI Powder coated
- SandFighter™ sealing system with SiC/SiC mechanical seal and sand slinger
- High efficiency electrical design for low operation costs
- Drinking water approvals

OPTIONS

- Higher-graded material: 316SS
- Special Voltages
- Retrofittable PT 100 temperature sensor



STANDARD SPECIFICATION

- Ratings: 30 - 150 kW
- Max. storage temperature - 15 °C - +60 °C
- Nominal ambient temperature: 30 °C with 0.16 m/s cooling flow
- Standard Voltage: 50 Hz: 380-415 V -10 % / +6 % U_N [380-415 V = (380-10%) - (415 + 6 %)]; 60 Hz: 460V / ±10 % U_N
- Protection IP68, Insulation class F
- Motor protection: DIN 61947-4-1
- Frequency of starts: 10 starts/ hour (with min. 3 minutes resting time), equally distributed
- DOL / YΔ - start (pos. of cables 90 °)
- Motor lead length: 4 m
- Vertical and horizontal operation, shaftend heightend
- Rotation counter clock wise facing shaft end (rotation reversible)
- Integrated sensor for SubMonitor™
- ▶ SubMonitor™ Protection



8" 3~ ENCAPSULATED HIGH TEMP 75 °C MOTOR

Encapsulated motor for reliable operation with ambient temperatures up to 75 °C

- HighTemp 75 °C version for reliable operation with ambient temperatures up to 75 °C (with 0.16 m/s cooling flow)
- Ratings: 30 - 110 kW
- Increased thrust capacity up to 30 °C
- Factory filled with Franklin's FES92 motor fill solution
- No cooling flow in larger wells necessary (12" / open reservoirs) up to 30 °C ambient temperature
- Standard motors WW (Water well) - Stator: 304SS / Castings - CI Powder coated
- High temperature leads
- All features of the Standard version
 - ▶ Standard 8" Encapsulated motor



OPTIONS

- Higher-graded material: 316SS
- Special Voltages
- Motor lead length: 8 m
- HighTemp drop cable



8" REWINDABLE MOTOR

Rewindable motors with best class winding wires



8" REWINDABLE STANDARD MOTOR

FEATURES & BENEFITS

- Double-flange NEMA mounting design
- Stainless steel splined shaft
- Factory filled with Franklin's FES93 motor fill solution
- Liquid lubricated radial bearings and High capacity Kingsbury 45 kN type thrust bearing for 100 % maintenance free operation
- Pressure-equalizing diaphragm, spring pre-loaded
- SandFighter™ sealing system with SiC/SiC mechanical seal and sand slinger
- Standard motors WW (Water well) - Stator: 304SS / Castings - CI Powder coated
- High efficiency electrical design for low operation costs
- Drinking water approvals

STANDARD SPECIFICATION

- Ratings: 30 - 93 kW
- Max. storage temperature - 15 °C - +60 °C
- Standard motor with PVC winding insulation
- Nominal ambient temperature: 30 °C with 0.2 m/s cooling flow for 30 - 52 kW motors with 0.5 m/s cooling flow for 55 - 93 kW motor
- Standard Voltage: 380 - 415 V (50 Hz), 460 V (60 Hz)
- Voltage Tolerance: 50 Hz: 380-415 V -10 % / +6 % UN [380-415 V = (380-10%) - (415 +6 %)]; 60 Hz: 460 V / ±10 % UN
- Protection IP68
- Motor protection: DIN 61947-4-1
- Frequency of starts: 10 starts/ hour (with min. 3 minutes resting time), equally distributed
- DOL / YΔ - start (pos. of cables 90 °)
- Motor lead length: 6 m
- Installation orientation: Vertical / horizontal (shaft end heightened) - 93 kW motors may not be installed in horizontal position)
- Rotation counter clock wise facing shaft end (rotation reversible)
- All motors with factory installed leads

OPTIONS

- Higher-graded material: 316SS, 904L
- Special Voltages
- Retrofittable PT 100 temperature sensor
- PE2/PA winding insulation for max. ambient temperature of 50 °C (Standard cooling flows)
- Special lead lengths



8" REWINDABLE PM MOTOR

Synchronous rewindable motor for first-class efficiency

OPTIONAL WATER WELL **WW** (CIPC / 304SS)

OPTIONAL STAINLESS STEEL **316**

OPTIONAL STAINLESS STEEL **904L**



8" REWINDABLE PERMANENT MAGNET MOTOR

FEATURES & BENEFITS

- Double-flange NEMA mounting design
- High efficiency electrical design for low operation costs
- SandFighter™ sealing system with SiC/SiC mechanical seal and sand slinger
- Factory filled with Franklin's FES93 motor fill solution
- Standard motors WW (Water well) - Stator: 304SS / Castings - CI Powder coated
- Drinking water approvals
- Stainless steel splined shaft
- Liquid lubricated radial bearings and High capacity Kingsbury 45 kN type thrust bearing for 100 % maintenance free operation
- Pressure-equalizing diaphragm, spring pre-loaded

STANDARD SPECIFICATION

- Ratings: 75 / 100 / 130 kW (100 Hz - 3000 rpm, 120 Hz - 3600 rpm)
- Max. storage temperature - 15 °C - +60 °C
- Standard motor with PE2/PA winding insulation
- Nominal ambient temperature: 30 °C with 0.5 m/s cooling flow
- System Supply Voltage: 400 V (100 Hz) / 460 V (120 Hz)
- Voltage Tolerance U_N : ±10 %
- Protection IP68
- Motor protection: DIN 61947-4-1
- Frequency of starts: 10 starts/ hour (with min. 3 minutes resting time), equally distributed
- DOL start
- Motor lead length: 6 m
- Motors installation orientation: Vertical / horizontal (shaft end heightened)
- Rotation counter clock wise facing shaft end (rotation reversible)

OPTIONS

- Higher-graded material: 316SS, 904L
- Special Voltages
- Retrofittable PT 100 temperature sensor
- Special lead lengths



10" REWINDABLE STANDARD MOTOR

Rewindable motors with best class winding wires

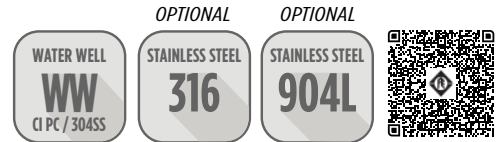

10" REWINDABLE STANDARD MOTOR

FEATURES & BENEFITS

- Double-flange NEMA mounting design
- Factory filled with Franklin's FES93 motor fill solution
- Liquid lubricated radial bearings and High capacity Kingsbury 60 kN type thrust bearing for 100 % maintenance free operation
- Pressure-equalizing diaphragm, spring pre-loaded
- Stainless Steel keyed shaft
- SandFighter™ sealing system with SiC/SiC mechanical seal and sand slinger
- Standard motors WW (Water well) - Stator: 304SS / Castings - CI Powder coated
- High efficiency electrical design for low operation costs
- Drinking water approvals

STANDARD SPECIFICATION

- Ratings: 85 - 185 kW
- Max. storage temperature - 15 °C - +60 °C
- Standard motor with PVC winding insulation
- Nominal ambient temperature: 25 °C with 0.5 m/s cooling flow
- Standard Voltage: 380 - 415 V (50 Hz), 460 V (60 Hz)
- Voltage Tolerance: 50 Hz: 380-415 V -10 % / +6 % UN [380-415 V = (380-10%) - (415 +6 %)]; 60 Hz: 460 V / ±10 % UN
- Protection IP68
- Motor protection: DIN 61947-4-1
- Frequency of starts: 10 starts/ hour (with min. 3 minutes resting time), equally distributed
- DOL / YΔ - start (pos. of cables 90 °)
- Motor lead length: 6 m
- Motors installation orientation: Vertical / horizontal (shaft end heightened)
- Rotation counter clock wise facing shaft end (rotation reversible)
- All motors with factory installed leads

OPTIONS

- Higher-graded material: 316SS, 904L
- Special Voltages
- Retrofittable PT 100 temperature sensor
- PE2/PA winding insulation for max. ambient temperature of 45 °C (Standard cooling flows)
- Special lead lengths



10" REWINDABLE PERMANENT MAGNET MOTOR

Synchronous rewindable motor for first-class efficiency



10" REWINDABLE PERMANENT MAGNET MOTOR

FEATURES & BENEFITS

- Double-flange NEMA mounting design
- Factory filled with Franklin's FES93 motor fill solution
- Liquid lubricated radial bearings and High capacity Kingsbury 60 kN type thrust bearing for 100 % maintenance free operation
- Pressure-equalizing diaphragm, spring pre-loaded
- Stainless Steel keyed shaft
- SandFighter™ sealing system with SiC/SiC mechanical seal and sand slinger
- Standard motors WW (Water well) - Stator: 304SS / Castings - CI Powder coated
- High efficiency electrical design for low operation costs
- Drinking water approvals

STANDARD SPECIFICATION

- Motor range: 200 - 250 kW (100 Hz - 3000 rpm), 230 - 290 kW (120 Hz - 3600 rpm)
- Max. storage temperature - 15 °C - +60 °C
- Standard motor with PE2/PA winding insulation
- Nominal ambient temperature: 30 °C with 0.5 m/s cooling flow
- System Supply Voltage: 400 V (100 Hz) / 460 V (120 Hz)
- Voltage Tolerance U_N : ±10 %
- Protection IP68
- Motor protection: DIN 61947-4-1
- Frequency of starts: 10 starts/ hour (with min. 3 minutes resting time), equally distributed
- DOL start
- Motor lead length: 6 m
- Motors installation orientation: Vertical / horizontal (shaft end heightened), 250 kW motors may not be installed horizontally
- Rotation counter clock wise facing shaft end (rotation reversible)
- All motors with factory installed leads

OPTIONS

- Higher-graded material: 316SS, 904L
- Special Voltages
- Retrofittable PT 100 temperature sensor
- Special lead lengths



12" REWINDABLE MOTOR

Rewindable motors with best class winding wires



12" REWINDABLE STANDARD MOTOR

FEATURES & BENEFITS

- Double-flange NEMA mounting design
- Factory filled with Franklin's FES93 motor fill solution
- Liquid lubricated radial bearings and High capacity Kingsbury type thrust bearing for 100 % maintenance free operation
- Pressure-equalizing diaphragm
- Stainless Steel keyed shaft
- SandFighter™ sealing system with SiC/SiC mechanical seal and sand slinger
- Standard motors WW (Water well) - Stator: 304SS / Castings - CI Powder coated
- High efficiency electrical design for low operation costs
- Drinking water approvals

STANDARD SPECIFICATION

- Ratings: 185 - 400 kW
- Max. storage temperature - 15 °C - +60 °C
- Nominal ambient temperature: 30 °C with 0.5 m/s cooling flow
- Standard Voltage: 380 - 415 V (50 Hz), 460 V (60 Hz), 500 V (50 Hz), 1000 V (50 Hz)
- Voltage Tolerance: 50 Hz: 380-415 V -10 % / +6 % UN [380-415 V = (380-10%) - (415 +6 %)]; 60 Hz: 460 V / ±10 % UN
- Protection IP68
- Motor protection: DIN 61947-4-1
- Frequency of starts: 5 starts/ hour (with min. 3 minutes resting time), equally distributed
- DOL / YΔ - start (pos. of cables 90 °)
- Motor lead length: 6 m
- Motors installation orientation: Vertical / horizontal (shaft end heightened)
- Rotation counter clock wise facing shaft end (rotation reversible)
- All motors with factory installed leads

OPTIONS

- Higher-graded material: 316SS
- Special Voltages
- Retrofittable PT 100 temperature sensor
- 80 kN Thrust load version
- Special lead lengths





SUBMERSIBLE BOREHOLE PUMPS

Franklin Electric offers a wide array of submersible pumps with flows up to 350 m³/h and heads up to 700 m. They perfectly match motors with power ratings up to 350 kW. The submersible pumps feature proven components, withstand the harshest environments and provide superior performance for numerous applications.



All pumps and parts are manufactured to precision tolerances. Every single component is inspected and tested prior to assembly. To assure the very best quality, all pumps are tested again according to the highest industry standards.

Built-in check valve

to protect the pump against water hammer risk (VSI spring pre-loaded)

Aluminium oxide guide journal sleeve

Drinking water approvals



(VS 6"-8" series)

Stainless Steel impellers and diffusers

VS 6"-8": Radial / Semiaxial design, VSI: Semiaxial design

Floating neck ring

VS 6"-8": PPS or PTFE, VSI 8"-10": EPDM

Stainless Steel diffusers and impellers

for high corrosion and abrasion resistance

Watch the Youtube video:



overview submersible pumps

Upper journal sleeve in 316SS

Diffusers

in Noryl

Floating impellers

in Polycarbonate



VS 4"

VS 6"-8"

VSI 8"-10"

APPLICATIONS



Municipal water works, Wastewater



Fountains



Water Distribution, Pressure Boosting



Irrigation, Sprinklers, Water treatment



Filtration and reverse osmosis



Industrial cooling and processing



Residential and farm wells and drainage



Mining industry, Drainage and dewatering



Fire-fighting equipment



Water supply to and from tanks, reservoir and wells



Lifting and distribution of a wide range of liquids



Autoclave and cistern charge and discharge



Turf and landscape Greenhouses and nurseries



Food industry General industry



SUBMERSIBLE BOREHOLE PUMPS

VS4 SUBMERSIBLE PUMP



FEATURES & BENEFITS

- Compact, reliable and suited to operate in horizontal or vertical position
- Designed to operate efficiently with Franklin Electric submersible motors / NEMA Standard motor adapter
- Hydraulic design enhances overall efficiency thus reducing energy consumption and making the pumping systems more cost effective
- Built-in check valve to protect the pump against water hammer risk
- Floating impellers to grant a better performance and longer life for the pump against abrasion
- Suitable for chemically and mechanically non aggressive liquids

OPTIONS

- Cooling shroud



STANDARD SPECIFICATION

- Models: VS 1-2-3-4-6-7-8-10-15
- Flow: up to 24 m³/h (50 Hz)
- Head: up to 278 m (50 Hz)
- Outlet diameter:
1" ¼ for VS 1-2-3-4,
2" for VS 6-7-8-10-15
- Water temperature range: from 0 °C to 40 °C
- Maximum allowable amount of sand: 100 g/m³,
Max. solid size: 2 mm
- Rotation: counter clockwise
when looking into the discharge



VS6 SUBMERSIBLE PUMP

FEATURES & BENEFITS

- Compact, reliable and suited to operate in horizontal position
- Designed to operate efficiently with Franklin Electric submersible motors / NEMA Standard motor adapter
- Hydraulic design enhances overall efficiency thus reducing energy consumption and making the pumping systems more cost effective
- Built-in check valve to protect the pump against water hammer risk
- Stainless Steel impellers and diffusers for corrosion resistance
- Heavy duty Stainless Steel structure for improved stiffness / permanent alignment of components (increased run time / trouble-free operation).
- Reinforced version with double welded rings for high pressure versions and for mix-flow models longer than 3 meters.
- Floating neck ring in PPS for higher resistance at temperature variations (models 14-19)
- Bushings is Aluminum Oxide for higher mechanical performance
- Bearings in EPDM, with drinking water certification approvals



STANDARD SPECIFICATION

- Models: VS 14-19-25-30-46-65
- Flow: up to 80 m³/h (50 Hz) / 100 m³/h (60 Hz)
- Head: up to 700 m (50 Hz / 60 Hz)
- Water temperature range: Min. -5° C,
Max. +90 °C (+60 °C for pumps with NBR parts)
- Maximum allowable amount of sand: 100 g/m³
- Vertical or horizontal operation



OPTIONS

- Higher-graded material: 316SS, 904L
- Double cable guard
- Discharge heads:
Rp2"/Rp3" VS 14/19/25, Rp4" VS 30/46-65
- Motor adapter: 6x4 and 6x8 for I and N versions



SUBMERSIBLE BOREHOLE PUMPS

VS8 SUBMERSIBLE PUMP

FEATURES & BENEFITS

- Designed to operate efficiently with Franklin Electric submersible motors / NEMA Standard motor adapter
- Built-in check valve and over size pump shaft
- Stainless Steel components for durability and robustness, assuring longevity and trouble-free operation
- Stainless Steel impellers and diffusers for corrosion resistance
- Thick solid Stainless Steel shell to maintain alignment
- Heavy duty cast suction and discharge brackets
- Motor adapter and discharge head may be removed without disturbing the impeller / diffuser stack
- Many design technical features make this pump range very compact and extremely reliable to ensure applications in the most complex and severe conditions.
- Easy maintenance without the need of special tools
- Bushings is Aluminum Oxidde for higher mechanical performance
- Bearings in EPDM, with drinking water certification approvals

STANDARD SPECIFICATION

- Models: VS 78-97
- Flow: up to 120 m³/h (50 Hz), up to 160 m³/h (60 Hz)
- Head: up to 500 m (50 Hz), 524 m (60 Hz)
- Water temperature range: Min. -5° C, Max. +60 °C
- Maximum allowable amount of sand: 100 g/m³
- Vertical or horizontal operation

OPTIONS

- Higher-graded material: 316SS, 904L
- Double cable guard
- Discharge head adapter: Rp4" or Rp6" for I and N version



VSI 8-10 SUBMERSIBLE PUMP

FEATURES & BENEFITS

- SS Cast Submersible Pumps 8"-10"
- High efficiency and corrosion resistance
- Hydraulic efficiency [%]: 83.5%
- Diffusers and impellers made of investment casting stainless steel
- Balanced impellers
- Spring loaded, robust design check valve with two bearing bushings and single piece disk
- Vesconite Hilube® top bearing bush (closed on top)
- PTFE+Graphite up-thrust bearing
- Shrink fit coupling
- Drinking water approvals

OPTIONS

- Different constructive metallurgies: CF8/304 (I version), CF8M/316 (N version), DUPLEX (R version)
- Different impeller diameters for 10" pump
- SD version with second cable guard

STANDARD SPECIFICATION

- Range [m³/h]:
8": VSI134: 75-175
10": VSI184: 100-250, VSI254: 170-350
- Flow: 8": up to 133 m³/h (50 Hz); 10": up to 260 m³/h (50 Hz)
- Head: 8": up to 398 m (50 Hz), 10": up to 600 m (50 Hz)
- Maximum liquid temperature: 65 °C
- Maximum allowable amount of sand: 100 g/m³
- Hydraulic connection (dimensions):
VSI134: Rp or NPT 5", PN45
VSI184: Rp or NPT 6" / Flanged D170 without counterflange, PN65
VSI254: Rp or NPT 6" / Flanged D170 without counterflange, PN60



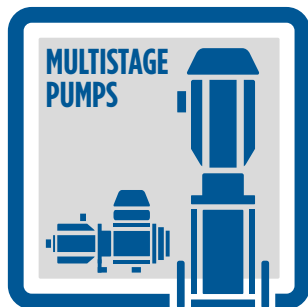

CLOSE-COUPLED 5" PUMPS

5" Stainless steel close-coupled submersible and multistage pumps



FEATURES & BENEFITS

- Stainless steel impellers and diffusers for corrosion resistance
- Heavy duty over size motor shaft
- Stainless Steel water proof capsule for motor protection
- Motor cooling is guaranteed by the pumped liquid
- Double mechanical seal separated by an oil chamber for maximum motor protection
- Plug-in type power cable and level control (floater) for easy replacement

STANDARD SPECIFICATION

- Models: ES 3-5 / VN 3-5-9 / VL 3-5-9
- Single phase or three phase asynchronous motor
- Asynchronous technology
- Protection IP68, Insulation class: F
- Standard voltage:
Single-phase: 50 Hz: 220 - 240 V \pm 5 %, 60 Hz: 220 - 230 V \pm 5 %
(Thermal protection built into the motor up to 1.1 kW and provided into the starter panel from 1.5 kW and above)
- Three-phase: 50 Hz: 220 - 240 V \pm 5 % and 380 - 415 V \pm 5 %, 60 Hz: 220 - 230 V \pm 5 % or 380 - 400V \pm 5 %
(Thermal protection to be provided into the starter panel by the installer)
- Frequency of starts: max. 60 starts/ hour
(with min. 1 minutes resting time)

Drinking water approvals (VN series)



20 m cable

with open cable end

Built-in capacitor

Stainless Steel impellers and diffuser

for durability, superior efficiency and highest performances

Threaded delivery port

Compact close-coupled design

robust and corrosion resistant

Watch the Youtube video:



5 inch submersible pumps

Threaded suction port



APPLICATIONS



Water Distribution
Pressure Boosting



Rainwater Recovery



Irrigation, Gardening,
Sprinklers



Wash down unit



Slightly corrosive
liquids



Water supply to and from
tanks, reservoir and wells

CLOSE-COUPLED 5" PUMPS

ES SUBMERSIBLE PUMP

- Flow: up to 7.5 m³/h (50 Hz) / 9 m³/h (60 Hz)
- Head: up to 88 m (50 Hz) / 80.5 m (60 Hz)
- Discharge outlet: 1 1/4" Rp
- Maximum working pressure: 10 Bar
- Maximum immersion depth: 20 m
- Maximum allowable amount of sand: 50 g/m³
- Maximum solids size: up to 2 mm
- Liquid temperature range: -5 °C to + 40 °C
- Continuous operation either in vertical or horizontal position
- All single-phase models with integrated capacitor

- 20 m power cable type H07RN-F is Standard
- Single-phase version available without float switch



VN SUBMERSIBLE PUMP

- Flow: up to 14 m³/h (50 Hz) / 16 m³/h (60 Hz)
- Head: up to 104 m (50 Hz) / 115 m (60 Hz)
- Discharge outlet: 1 1/4" Rp
- Maximum working pressure: 12 Bar
- Maximum immersion depth: 20 m
- Maximum allowable amount of sand: 50 g/m³
- Maximum solids size: up to 2 mm
- Liquid temperature range: -5 °C to + 40 °C
- CB control box with integrated capacitor for single-phase version, available as option
- Continuous operation either in vertical or horizontal position

- 20 m power cable type H07RN-F is Standard
- Single-phase version available without float switch



VL MULTISTAGE PUMP

- Flow: up to 14 m³/h (50 Hz) / 16 m³/h (60 Hz)
- Head: up to 104 m (50 Hz) / 115 m (60 Hz)
- Discharge outlet: 1 1/4" Rp
- Maximum working pressure: 15 Bar
- Maximum immersion depth: 20 m
- Maximum allowable amount of sand: 50 g/m³
- Liquid temperature range: -5 °C to + 40 °C
- Continuous operation either in vertical or horizontal position

- 20 m power cable type H07RN-F is Standard
- Single-phase version available without float switch
- Rp threaded (inlet/outlet)





4"/6"/8"/10" HIGH EFFICIENCY BOREHOLE SYSTEMS

Energy savings with the permanent magnet motor technology

- Synchronous submersible motor (4"-8" NEMA)
- Variable frequency drive
- Matching output filter (> 230 V)
- Flow switch (systems ≥ 4 kW)
- Matching submersible pumps available separately



FEATURES & BENEFITS

- Up to 21% improved motor efficiency* with excellent partial load behaviour (SKU reduction)*
- Due to the high motor efficiency, amps are significantly reduced, which might lead to smaller drop lead cross size and thus cost saving
- One-stop shop and perfectly matching components guarantee first-class performance/efficiency
- Power factor corrected input (No power compensation needed)
- Significant lower motor heat rise (Increased lifetime)
- Easy system set-up due tailored pre-settings, user interface and own Franklin Electric software / App
- Incorporated Soft start and protection features (increased lifetime, no additional investment)
- Speed control (Optimum aggregate operation - pump matches system any time)
- Communication ModBus (RS485 and Ethernet) 6"/8"

MOTOR RANGE:

- 4" HES: 0.55 - 7.5 kW
1.1 / 2.2 / 3.0 / 4.0 / 5.5 / 7.5 kW (100 Hz - 3000 rpm)
1.2 / 2.5 / 3.4 / 4.6 / 8.6 kW (120 Hz - 3600 rpm)
- 6" HES: 4 - 45 kW
4.0 - 11.0 / 13.0 - 22.0 / 26.0 - 45.0 kW (100 Hz - 3000 rpm)
4.6 - 12.7 / 15.0 - 25.0 / 30.0 - 51.7 kW (120 Hz - 3600 rpm)
- 8" HES: 45 - 130 kW
75 / 100 / 130 kW (100 Hz - 3000 rpm)
86.3 / 115 / 150 kW (120 Hz - 3600 rpm)
- 10" HES: 150 - 250 kW
190 - 250 kW (100 Hz - 3000 rpm)
230 - 290 kW (120 Hz - 3600 rpm)

Watch the Youtube videos:



High Efficiency Systems



High Efficiency Systems



To help you select the right system for your grid and solar applications, use the HES selection and sizing tool on the Franklin website.



*-compared to current asynchronous technology and measured with Franklin Electric Original equipment 230 V kits and Solar versions without additional output filter



4" HIGH EFFICIENCY SYSTEM CT

High Efficiency Submersible Borehole Systems with encapsulated Permanent magnet motors

STANDARD SPECIFICATION

- motor range:
1.1 / 2.2 / 3.0 / 4.0 / 5.5 / 7.5 kW (100 Hz - 3000 rpm)
1.2 / 2.5 / 3.4 / 4.6 / 8.6 kW (120 Hz - 3600 rpm)
- System Power Supply: 220-400 / 460 V ± 10 % (50/60 Hz)
- Frequency: 50 Hz - 60 Hz ± 2 %
- Nominal ambient temperature 30 °C, electronics: 50 °C (> 40 °C with derating)
- Protection motor: IP68, insulation class B
drive: IP66
filter: IP00
- Vertical and horizontal operation
- Factory-featured with Bluetooth 4.0 Connectivity
- Remote control and maintenance via Mobile App

PACKAGED DEAL 4"



- 4" encapsulated synchronous submersible NEMA motor
- 4"/6" submersible pump
- Variable frequency drive
- Matching output filter for 400 V systems

OPTIONS

- Special Voltages
- Matching output filters in IP00/23/54 (400V)
- Higher-graded material: 316SS
- VFD in IP20
- Solar



Watch the Youtube video:

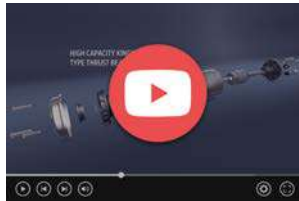

High Efficiency System with 4" permanent magnet motor



4" HIGH EFFICIENCY SOLAR SYSTEM CT

High Efficiency Submersible Borehole Systems with encapsulated Permanent magnet motors for Solar applications

FEATURES & BENEFITS

- One-stop shop and perfectly matching components guarantee first-class performance/efficiency
- Less panels, more water respectively
- Integrated voltage "boost" (up to 2.2 kW) significantly reduces number of solar panels
- MVPT algorithm maximises system output and reliability during time with less solar energy available.
- Solar controller can be powered by DC or AC supply at a time
- System Power Supply:
≤ 2.2 kW: 90 - 400 V DC / AC Backup: 90 - 265 V
≥ 3.0 kW: 160 - 850 V DC / AC Backup: 190 - 520 V
≥ 4 kW: 380 - 500 V AC / 400 - 800 V DC
- Backup Power supply / Direct AC feeding to maximize system runtime
- Top class protection with Electronics in IP66 / 65



6" CT HIGH EFFICIENCY SYSTEM

High Efficiency Submersible Borehole Systems with encapsulated Permanent magnet motors



STANDARD SPECIFICATION

- motor range:
4.0 – 11.0 / 13.0 – 22.0 / 26.0 - 45.0 kW (100 Hz - 3000 rpm)
4.6 – 12.7 / 15.0 – 25.0 / 30.0 - 51.7 kW (120 Hz - 3600 rpm)
- System Power Supply: 380-400 V / 460 V ± 10 % (50/60 Hz)
- Frequency: 50/60 Hz ± 6 %
- Protection motor: IP68, insulation class F
drive: IP66/54/22
filter: IP54/00

PACKAGED DEAL 6"



- 6" encapsulated synchronous submersible NEMA motor
- Variable frequency drive
- Matching output filter
- Flow switch (systems > 22 kW)
- 6" submersible pump (optional)

OPTIONS

- Higher-graded material: 304SS, 316SS
- Special Voltages
- Plug-in card PT100 - 308 170 202
(systems 37-45 kW in IP66 configuration)
- Plug-in card 6x DI/DO - 308 170 201
(systems 37-45 kW in IP66 configuration)
- Plug-in card Profibus - 308 170 203
(systems 37-45 kW in IP66 configuration)
- Plug-in card 1x AI & 2x AO 308 170 206
(systems 37-45 kW in IP66 configuration)



6" CT HIGH EFFICIENCY SOLAR SYSTEM

High Efficiency Submersible Borehole Systems with encapsulated Permanent magnet motors for Solar applications

FEATURES & BENEFITS

- Special MPP algorithm for centrifugal borehole pumps
- Top class protection with Electronics in IP66 (No cabinet- no cooling fan/dust filter- no maintenance), GORE® vent (No condensation)
- Direct DC feeding
- Less panels, more water respectively
- MVPT algorithm maximises system output and reliability during time with less solar energy available.
- System Power Supply: 400 - 800 V DC (min. starting voltage 440 V)
- Frequency: 30 - fN (50 Hz respectively 60 Hz)

8" REW HIGH EFFICIENCY SYSTEM

High Efficiency Submersible Borehole Systems with rewindable Permanent magnet motors



STANDARD SPECIFICATION

- Motor range:
75 / 100 / 130 kW (100 Hz - 3000 rpm), 86.3 / 115 / 150 kW (120 Hz - 3600 rpm)
- System Power Supply: 400 / 460 V ± 10 % (50/60 Hz)
- Frequency: 50 Hz - 60 Hz ± 6 %
- Nominal ambient temperature
30 °C, electronics: 50 °C (> 40 °C with derating)
- Protection motor: IP68, insulation class Y
 drive: IP20/00
 filter: IP21/54
- Motor installation orientation:
vertical / horizontal (shaft end heightened)

PACKAGED DEAL 8"



- 8" rewindable synchronous submersible NEMA motor
- Variable frequency drive
- Matching output filter
- Flow switch (Solar systems)
- 8" submersible pump (optional)

OPTIONS

- Special Voltages
- Higher-graded material: 316SS, 904L
- Retrofittable PT 100 temperature sensor
- Sinus output filters in IP54 and IP00,
Solar drive available in IP00/21 enclosure rating
- Plug-in card 6x DI/DO (order no. 308 170 201)
- Plug-in card PT100 (order no. 308 170 202)
- Plug-in card 1x AI & 2x AO (order no. 308 170 206)
- Plug-in card Profibus (order no. 308 170 203)



8" REW HIGH EFFICIENCY SOLAR SYSTEM

High Efficiency Submersible Borehole Systems with rewindable Permanent magnet motors for Solar applications

FEATURES & BENEFITS

- Special MPP algorithm for centrifugal borehole pumps
- Direct DC feeding
- Less panels, more water respectively
- motor range: 37 - 130 kW (100 Hz - 3000 rpm)
- System Power Supply: 400 - 800 V DC
(min. starting voltage 440 V)
- Frequency: 30 - fN (50 Hz respectively 60 Hz)



10" HIGH EFFICIENCY SYSTEM REW

High Efficiency Submersible Borehole Systems with rewindable Permanent magnet motors

STANDARD SPECIFICATION

- Motor range:
190 - 250 kW (100 Hz - 3000 rpm)
230 - 290 kW (120 Hz - 3600 rpm)
- System Power Supply: 400 / 460 V $\pm 10\%$ (50/60 Hz)
- Frequency: 50 Hz - 60 Hz $\pm 2\%$
- Nominal ambient temperature:
motor: 30 °C, electronics: 50 °C (> 40 °C with derating)
- Protection motor: IP68, insulation class Y
drive: IP00
filter: IP00
- Motor installation orientation:
vertical / horizontal (shaft end heightened)
250 kW motors may not be installed horizontally

PACKAGED DEAL 10"



- 10" rewindable synchronous submersible motor
- Variable frequency drive
- Matching output filter
- Flow switch (Solar systems)
- 10" submersible pump (optional)

OPTIONS

- Special Voltages
- IP54 electronics
- Higher-graded material: 316SS, 904L
- Retrofittable PT 100 temperature sensor
- Sinus output filters
- Plug-in card 6x DI/DO (order no. 308 170 201)
- Plug-in card PT100 (order no. 308 170 202)
- Plug-in card 1x AI & 2x AO (order no. 308 170 206)
- Plug-in card Profibus (order no. 308 170 203)





10" REW HIGH EFFICIENCY SOLAR SYSTEM

High Efficiency Submersible Borehole Systems with rewindable Permanent magnet motors for Solar applications

FEATURES & BENEFITS

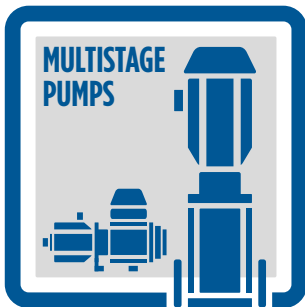
- Special MPP algorithm for centrifugal borehole pumps
- Top class protection with Electronics in IP68
- Less panels, more water respectively
- Direct DC feeding
- MVPT algorithm maximises system output and reliability during time with less solar energy available.
- motor range: 190 - 250 kW (100 Hz - 3000 rpm),
230 - 290 kW (120 Hz - 3600 rpm)
- System Power Supply: 400 - 800 V
(min. starting voltage 440 V)
- Frequency: 30 - fN



VERTICAL MULTISTAGE CENTRIFUGAL PUMPS

Stainless Steel Multistage pumps for high efficiency and superior performance

Franklin Electric Vertical multistage pumps are the silent partner of your daily life. Available in different metallurgies (Cast Iron, 304 SS, 316 SS), head and flow, offer the right solution for any pressure boosting application.

Drinking water approvals



(ACS/ICIM for EV series only)



Cartridge mechanical seal

without dismantling the pump
(for models > 4 kW no motor dismantling necessary)

Tungsten carbide intermediate bearing

to stabilize the hydraulics with a large number of stages

Commercial motors

with interchangeable motor brackets

No up-thrust bearing

for models up to 4 kW

Replaceable floating neck ring

for cost effective maintenance and long-lasting performance

Stainless Steel impeller and diffuser

for corrosion resistance and increase of efficiency

Easy installation in-line ports

Round flange, oval, Victaulic, Clamp, Threaded



APPLICATIONS



Water Distribution
Pressure Boosting
Drinking water



Irrigation
Water treatment plants
Gardening, Sprinklers



Wash down unit
Boiler Feed



Domestic, industrial and
agricultural systems



Circulation of hot and
cold water for heating,
cooling, conditioning systems

Watch the Youtube video:



Vertical Multistage pumps

VERTICAL MULTISTAGE PUMPS

EV SERIES - VERTICAL MULTISTAGE PUMPS



High performance Pressure-boosting for flows up to 115 m³/h (50 Hz), 140 m³/h (60 Hz)

FEATURES & BENEFITS

- Compact and solid structure
- All wetted parts in Stainless-steel
- Shaft bearing and journal sleeve made of tungsten carbide
- WRAS approved. PPS (EV 1-3-6-10-15-20), PTFE (EV 30-45-65-95)
- Easily replaceable cartridge mechanical seal, no pump disassembly required; no motor disassembly required for models higher than 4 kW
- Reduced service and maintenance time thanks to the monobloc design of mechanical seal and the models up to 4 kW without thrust bearing
- Replaceable Stainless Steel wear ring in the neck of the impeller (EV 30-45-65-95)
- Tungsten carbide intermediate bearing to control and eliminate vibration and stabilize the rotor with a large number of stages
- Stainless-steel impeller and diffusers for corrosion resistance

PUMP SPECIFICATION

- Models: EV 1-3-6-10-15-20-30-45-65-95
- Flow: up to 115 m³/h (50 Hz) / 140 m³/h (60 Hz)
- Head: up to 326 m (50 Hz) / 282 m (60 Hz)
- Discharge and suction port: Oval, Round flanges, Victaulic and Clamp connections
- Liquid temperature range: from -15 °C to +120 °C
- Maximum working pressure: Oval flange 16 Bar; Round Flange, Victaulic and Clamp connections 25 bar
- Direction of rotation: clockwise looking at the pump from the top down
- Mechanical seal Type E1 (standard) = Graphite/Silicon carbide/ EPDM (EN 12756 ex DIN 24960) WRAS and ACS approved
- Mechanical seal Type BE1 (balanced) = Graphite/Silicon carbide/ EPDM WRAS and ACS approved (EV 30-45-65-95)

MOTOR SPECIFICATION

- Motor powers from 0.37 to 45 kW at 50 and 60 Hz
- Motor efficiency: single phase up to 2.2 kW: IE2, three-phase: IE3
- Motor size: B14 ≤ 4 kW, B5 ≥ 5.5 kW
- Protection: IP55, Insulation class: F
- Max ambient temperature: 40 °C
- Standard voltage: 230/400 V ≤ 3 kW, 400/690 V ≥ 4 kW
- PTC sensor 155 °C: standard from 11 kW (on request from 0.75 to 7.5 kW)

SPECIAL VERSION

- Special Voltages
- Passivated version
- High Pressure (HP) version
- Horizontal installation
- Further mechanical seal material

Watch the Youtube videos:



EV Series - Vertical Multistage pumps



EV Series - Vertical Multistage pumps



VERTICAL MULTISTAGE PUMPS

EM SERIES - VERTICAL CLOSE-COUPLED MULTISTAGE PUMPS



Vertical multistage pumps for pressure boosting

FEATURES & BENEFITS

- Pumping of clear non-loaded fluids
- Compact close-coupled design, robust and corrosion resistant
- Excellent efficiency and performance
- Floating neck ring in PPS
- Heavy duty oversize motor shaft
- Impellers and diffusers in Stainless Steel for Maximum durability
- Easy maintenance
- Strong and leak-proof motor ball bearing fitted in the motor

PUMP SPECIFICATION

- Models: EM 3-5-9
- Flow: up to 14 m³/h (50 Hz) / 17 m³/h (60 Hz)
- Head: up to 104 m (50 and 60 Hz)
- Discharge and suction port: Threaded or oval connections
- Max. working pressure: 12 Bar
- Max ambient temperature: 40 °C
- Liquid temperature range:
Min. - 15 °C; Max.: + 90 °C for domestic use (uses covered by CEI EN Standard 60335-2-41), + 110 °C only for industrial use (uses other than those covered by CEI EN Standard 60335-2-41)
- Mechanical seal Type E0 = Carbon / Ceramic / EPDM

MOTOR SPECIFICATION

- Three-phase motors efficiency class IE3
- Asynchronous, TEFC (Totally enclosed, fan-cooled)
- 2 pole
- Protection: IP55, Insulation class F

VERSIONS

- D: Inline threaded
- T: Inline oval
- R: 3 threaded ports
- WRAS (on request)



VERSION D



VERSION R



VERSION T

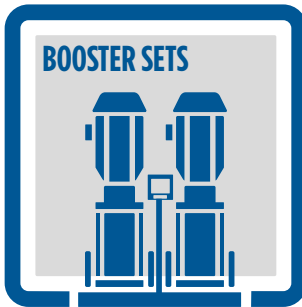

BOOSTING SYSTEMS

High performance Pressure-boosting made by series of pumps for flows up to 84 m³/h and heads up 160 m

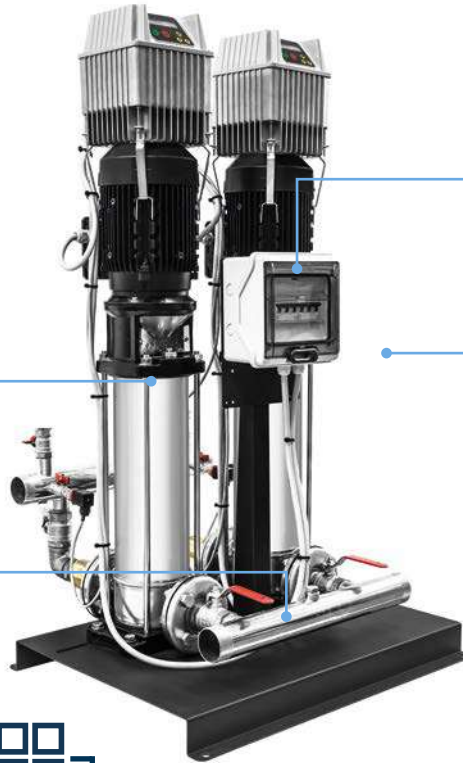

Compact design

Series of pumps connected in parallel

through manifolds, shut-off valves, check valves and fixed on a skid

VERSIONS

- Fixed speed / Variable speed
- 304SS manifolds

PUMP SPECIFICATION

- Models: GP02/EH, GP02/EM, GP02/EV, GP03/EV, GD02 DTm, GD02 / EM, GD02/EV, GD03/EV
- Flow: up to 84 m³/h / Head: up to 160 m
- Start-up: direct or with inverter
- Power supply voltage: 1 x 230 V 50 Hz for single-phase sets, 3 x 400 V 50 Hz for three-phase sets
- Ambient temperature at nominal load: max 40 °C
- Relative humidity: max 50% at 40 °C
- Max. altitude at nominal load: 1000 m
- Temperature of pumped liquid: clean water: 5 °C to +35 °C

Control panel and pressure switch

All pumps can be set and controlled by a control panel and pressure switch (fixed speed) or by inverter (variable speed).

Easy handling

All booster set are hydraulically and electrically tested and assembled in the factory

Suitable for various applications



Domestic water supply
Industrial plants



Water Distribution
Pressure Boosting



Rainwater Recovery



Irrigation,
Gardening, Sprinklers



Industrial plants
Wash down unit



Industrial cooling,
HVAC systems

Watch the Youtube video:



Boosting systems

GP SERIES

- GP series booster pump sets consist of two or three identical electric pumps coupled in parallel by manifolds, shut-off valves, check valves and fixed on a single base.
- The electric pumps are controlled via an electronic or electro-mechanical panel which automatically starts and stops the electric pumps based on the pressures set on the pressure switches.

GD SERIES

- Variable speed booster pump sets with Drive-Tech and Drive - Tech MINI inverter.
- GD series booster pump sets consist of two or three identical electrical pumps coupled in parallel by manifolds, shut-off valves, check valves and fixed on a single base.
- The electric pumps are controlled by inverter, one per electric pump, which modulates the operating frequency in order to maintain the set reading constant.

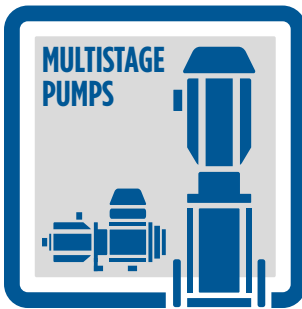

HORIZONTAL MULTISTAGE PUMPS

Stainless Steel Multistage pumps for high performance with flows up to 29 m³ and heads up to 104 m

The Horizontal Multistage booster pumps are designed to meet the pressure boosting needs with flows up to 29 m³/h and heads up to 104 m. They are available with self-priming functionality or connected inverter drive for Maximum efficiency, simplicity, innovation and safety.



Drinking water approvals

Stainless Steel Impellers and Diffusers

Superior efficiency and performances

Floating neck ring in PPS



Heavy duty oversize motor shaft

Reinforced design with tie rods

Compact close-coupled design Robust and corrosion resistant

Flexible application base plate

Self-Priming functionality (sp versions)

Special elastic valve allows air to escape. During the start this elastic valve, which is located at the first stage, opens to allow air to escape out of the system and water to enter the pump. As soon as the pressure arrives at a certain point, the valve closes, and the pump reaches the required performance.



Drive-Tech MINI inverter

with various duty points for maximum efficiency, simplicity, innovation and safety

Asynchronous motors (3~)

TEFC (totally enclosed, fan-cooled)

APPLICATIONS



Water Distribution Pressure Boosting



Circulation of hot+cold water for heating, cooling, conditioning systems



Irrigation Gardening, Sprinklers



Wash down unit



Domestic, industrial and agricultural systems



HORIZONTAL MULTISTAGE PUMPS

EH SERIES - HORIZONTAL MULTISTAGE PUMPS



High performance Pressure-boosting in different flow rates, HP ratings and phases

FEATURES & BENEFITS

- The EH series is offered in five flow rates and different horsepower sizes, in single-phase or three-phase, to make sure you have the right pump to fit your application.
- Compact close-coupled design, robust and corrosion resistant
- Excellent efficiency and performance
- Floating neck ring in PPS
- Heavy duty oversize motor shaft
- Impellers and diffusers are made in Stainless Steel
- Easy maintenance
- Strong and leak-proof motor ball bearing fitted in the motor
- Pumping of clear non-loaded fluids

PUMP SPECIFICATION

- Models: single phase: EH 3-5-9 up to 1.5 kW, three-phase: EH 3-5-9-15-20
- Mechanical seal Type E0 = Carbon / Ceramic / EPDM: EH 3-5-9
- Mechanical seal Type E1 = Seal carbon / Silicon carbide / EPDM: EH 15-20
- Flow: up to 29 m³/h at 50 Hz
up to 30 m³/h at 60 Hz
- Head: up to 104 m at 50 Hz
up to 111 m at 60 Hz
- Connections: Rp threaded for inlet and outlet
- Max. working pressure: 10 Bar
- Max. ambient temperature: 40 °C
- Liquid temperature range:
Min. from -15 °C to -10 °C according to gasket material
Max. +55 °C single-phase models for domestic use (uses covered by CEI EN Standard 60335-2-41)
+90 °C three-phase models for domestic use (uses covered by CEI EN Standard 60335-2-41)
+110 °C only for industrial use (uses other than those covered by CEI EN Standard 60335-2-41)
- Liquid temperature range (EHsp): from 0 °C up to 35 °C

MOTOR SPECIFICATION

- Onephase motor efficiency class IE2
- Three-phase motor efficiency class IE3
- Asynchronous, TEFC (Totally Enclosed, fan-cooled)
- 2 pole
- Protection IP55, Insulation class: F
- Standard voltage:
220-240 V / 380-415 V ±5 % up to 3 kW
380-415 V / 660-690 V ±5 % from 4 kW
(Thermal protection to be provided into the starter panel by the installer)



HORIZONTAL MULTISTAGE PUMPS

EH DTM SERIES - HORIZONTAL MULTISTAGE WITH DRIVE-TECH MINI



State-of-the-art booster set with inverter which combines superior efficiency, simplicity, innovation and safety

FEATURES & BENEFITS

- **Efficiency:** The Drive-Tech MINI achieves overall energy savings up to 40 % (compared to conventional speed control systems)
- **Simplicity:** The Drive-Tech MINI is mounted directly onto the motor control box. It is already supplied with a 2.0 meter power cable and a 1.50 meter cable to connect with the pressure transducer.
- **Innovation:** The Drive-Tech MINI can be controlled manually by the board panel or via Bluetooth by the Franklin Smartphone App "FE Connect Drivetech" (Android and IOS), enabling you to set and monitor the system remotely, save working data and increase the pump performance.
- **Safety:** The integrated Class B (EN55011) input-filter prevents any type of disturbances in the domestic network to ensure a reliable use. The filter follows EMC Directives (electromagnetic compatibility).
- Compact close-coupled design, robust and corrosion resistant, Stainless Steel impellers and diffusers for long durability
- Flexible application base plate
- Floating neck ring in PPS
- Oversize motor shaft
- Easy maintenance
- Strong motor rolling bearing fitted in the motor bracket
- Mechanical seal Type E0 = carbon/ceramic/EPDM
- Energy saving due to variable speed control, Soft start and soft stop
- Simplified installation on motor or wall, Easy and fast commissioning thanks to initial configuration wizard
- Installation on humid and dusty environment made possible by IP55 (NEMA 4) protection degree
- High thermal and mechanical performance thanks to aluminum case and independent ventilation

PUMP SPECIFICATION

- Flow: up to 17 m³/h
- Head: up to 99 m
- Connections: Rp threaded for inlet and outlet
- Maximum working pressure: 10 Bar
- Maximum altitude at rated current: 1000 m
- Maximum ambient temperature: 40 °C
- Liquid temperature range:
- Minimum: from 0 °C according to gasket material
- Maximum: +80 °C for domestic use (uses covered by CEI EN standard 60335-2-41)



DRIVE-TECH MINI SPECIFICATION

- Monitoring and programming with smartphone and FE Connect App, available for Android and iOS mobile devices
- Remote control using a smartphone nearby as a modem
- Copy and paste of programming recipes
- Ability to send reports via email
- Control modes: Constant pressure control, Constant or proportional differential pressure control, Constant temperature control, Constant differential temperature control, Constant flow control, External frequency control (trimmer) or 1 or 2 preset frequencies control
- Built-in protection against: Overvoltage and undervoltage, Overcurrent and no load, Dry running, Overtemperature
- EMC compatibility for residential environment: Integrated PFC (P.F. 1) to meet EN61000-3-2, Integrated input filter for Category C1 (EN61800-3), Class B (EN55011)
- Multi-pump operation (COMBO): Up to 8 units, Working alternation for uniform pumps wearing, Master or slave replacement in case of failure to ensure continuity of operation
- Advanced motor controls: Next generation control of asynchronous motors, Sensorless control of permanent magnet synchronous motors
- Inputs and outputs: 2 programmable digital inputs for motor start & stop, Modbus RTU, 2 output relays for alarm and run indication, 2 analog inputs 4-20 mA, 2 analog inputs 0-10 V



WASTEWATER PUMPS

Great range of submersible drainage and sewage pumps for domestic and industrial waste water application



EGN DRAINAGE PUMP

- Models: EGN 4-5-7-9-11-15
- Cast iron pump casing and impeller with epoxy cataphoresis treatment
- Open impeller
- Vertical delivery port
- Single-phase version, 230 V: with float switch and incorporated capacitor, 10 m cable with Schuko plug
- Three-phase version, 230/400 V: 10 m cable without plug
- Double mechanical seal in oil chamber
- Flow: up to 30 m³/h at 50 Hz
- Head: up to 20 m at 50 Hz
- Liquid temperature: up to 35 °C
- Motor power: up to 1.5 kW at 50 Hz
- Max. immersion depth: 5 m
- Max. solid content: 10 mm



APPLICATIONS



For clean and dirty water, containing solids up to 35 mm grain size



draining rooms, tank drainage



Extraction of water from ponds, streams or pits and for rainwater collection

ED - EDV DRAINAGE PUMP

- Models: ED 5-9 (with two-passage impeller)
EDV 5-7-9 (with free-flow Vortex impeller)
- Stainless steel pump casing and impeller
- Vertical delivery port
- Double mechanical seal in oil chamber
- Single-phase version, 230 V: with float switch and incorporated capacitor, 10 m cable with Schuko plug
- Three-phase version, 230/400 V: 10 m cable without plug
- Flow: up to 26 m³/h at 50 Hz
- Head: up to 13 m at 50 Hz
- Liquid temperature: up to 35 °C
- Motor power: up to 0.9 kW at 50 Hz
- Max. immersion depth: 5 m
- Max. solid content: 35 mm



APPLICATIONS



For clean and dirty water, containing solids up to 35 mm grain size



The free-flow impeller construction (EDV) is particularly suitable for liquids with an high solid content or with filamentous particles



The construction with smooth surfaces in rolled-stainless steel and easy access for cleaning is suitable for certain uses in the food industry

WASTEWATER PUMPS

EGT - EGF DRAINAGE PUMP

- Models: EGT/EGF 5-7-9-11-15
- Free-flow (Vortex) impeller construction
- EGT: Vertical delivery port, EGF: with horizontal flanged and threaded delivery port
- Cast iron pump casing and impeller with epoxy cataphoresis treatment
- Single-phase version, 230 V: with float switch, thermal protector and incorporated capacitor, 10 m cable
- Three-phase version, 230/400 V: 10 m cable without plug
- Double mechanical seal in oil chamber
- Flow: up to 36 m³/h at 50 Hz
- Head: up to 14.4 m³/h at 50 Hz
- Liquid temperature: up to 35 °C
- Motor power: up to 1.5 kW at 50 Hz
- Max. immersion depth: 5 m
- Max. solid content: 50 mm



APPLICATIONS



Domestic or industrial waste water, dirty water containing solids up to 50 mm grain size, for liquids which are compatible with the pump materials



draining rooms, tank drainage



Extraction of water from ponds, streams or pits and for rainwater collection

SEWAGE PUMPS

FWS-FWC SERIES - WASTEWATER LIFT PUMPS 50 HZ



FWS Series (Franklin Waste Stainless) - Submersible pumps for sewage

Stainless Steel and Cast Iron submersible wastewater lift pumps

- Submersible electric pump particularly suitable for the emptying of basements, garages, cellars and flooded premises.
- Vortex impeller
- 32FWS V Series: 0.3 kW, up to 12,6 m³/h, up to 7.6 m
- 40FWS V Series: 0.37 - 0.7 kW, up to 19.8 m³/h, up to 9.8 m
- 50FWS V Series: 0.9 - 1.4 kW, up to 36 m³/h, up to 12 m



FWC (Franklin Waste Cast iron) - Submersible pumps for sewage

Stainless Steel and Cast Iron submersible wastewater lift pumps

- Submersible electric pumps suitable for pumping screened waste water, draining the sewage of blocks of flats and houses and flooded premises in general.
- Vortex impeller
(50FWC V, 50FWC V4, 65FWC V, 65FWC V4, 80FWC V4)
- Single-channel impeller
(50FWC M, 65FWC M, 80FWC M4, 100FWC M4)
- 50FWC V Series: 0.9 - 1.6 kW, up to 36 m³/h, up to 14 m
- 50FWC M Series: 0.9 - 1.6 kW, up to 50.4 m³/h, up to 24 m
- 50FWC V4 Series: 0.75 - 1.1 kW, up to 39.6 m³/h, up to 7.4 m
- 65FWC V Series: 2.2 kW, up to 54 m³/h, up to 16.5 m
- 65FWC M Series: 1.6 - 2.2 kW, up to 64.8 m³/h, up to 24 m
- 65FWC V4 Series: 0.75 - 1.6 kW, up to 54 m³/h, up to 11 m
- 80FWC M4 Series: 2.2 - 5.5 kW, up to 169.2 m³/h, up to 19.8 m
- 80FWC V4 Series: 1.6 - 5.5 kW, up to 122.4 m³/h, up to 16 m
- 100FWC M4 Series: 2.2 - 5.5 kW, up to 212.4 m³/h, up to 19 m



APPLICATIONS



Pumping of clear non-loaded fluids



Wastewater



Extraction of water from ponds, streams or pits and for rainwater collection



Domestic / industrial grey water

Watch the Youtube videos

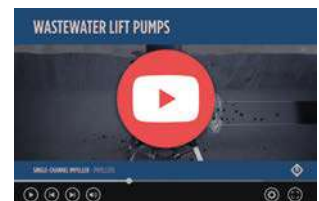

FWS-FWC Series - Wastewater lift pumps 50 Hz

SEWAGE PUMPS

FGR SERIES - PUMPS WITH GRINDER UNIT 50 HZ



FGR (Franklin Grinder) - Cast Iron submersible wastewater lift pumps with grinder unit

Cast Iron submersible wastewater lift pumps with grinder unit

These series of grinder pumps are particularly used in civil and industrial sewage plants. They have been designed to pump the liquid at high head with very low capacity. The cutter unit, in a special hard stainless steel, cuts into small pieces threadlike materials contained in the liquids. As the risk of clogging is avoided small diameter pipes are used. These pumps can be used to lift the sewage of blocks of flats and villas, small isolated areas far from the sewer systems; the sewage of hotels and campsites, in the food and paper industry and in those particular situations where the installation is often expensive by using a gravity system.

- Impeller with grinder unit
- 40FGR Series: 0.75 - 1.1 kW, up to 12.6 m³/h, up to 21 m
- 50FGR Series: 1.1 - 2.2 kW, up to 18 m³/h, up to 34 m



40FGR



50FGR

APPLICATIONS



pumping of clear non-loaded fluids



waste water



Extraction of water from ponds, streams or pits and for rainwater collection

Watch the Youtube videos



FGR (Franklin Grinder)

FLV SERIES - D.C. MOTOR SUBMERSIBLE WASTE WATER LIFT PUMPS 50 HZ



FLV (Franklin Low Voltage)

The D.C. electric submersible pumps are suitable for the of water from road drain wells, basements and from sites where the electric current is not available. Easy to install and silent, this model offer the maximum safety.

- Vortex impeller
- 12/24DC
- 40FLV Series: 0.3 - 0.75 kW, up to 19.8 m³/h, up to 12 m



40FLV

APPLICATIONS



drainage



Domestic / industrial grey water

Watch the Youtube videos



FLV Series - D.C. motor submersible waste water lift pumps 50 Hz

SUBMERSIBLE DRAINAGE PUMPS

FDR SERIES - SUBMERSIBLE PUMPS FOR RESIDENTIAL DRAINAGE 50 HZ



FDR Series (Franklin Dewatering Residential)

Submersible pumps for clear and turbid water drainage

- Submersible electric pumps in cast iron and stainless steel, suitable for draining clear and turbid waters. They can be used as ready-to-use portable pumps both for construction site use, basement wells, and for fixed installations with control panel.
- Open impeller
- Transportable as emergency pump with connection to the hose and for free installation in the well.
- 40FDR Series: 0.37 - 0.7 kW, up to 19.8 m³/h, up to 11 m
- 50FDR Series: 0.9 - 1.4 kW, up to 36 m³/h, up to 18 m



APPLICATIONS



Drainage and dewatering



Rainwater Recovery



Extraction of water from ponds, streams or pits and for rainwater collection



draining rooms, tank drainage

FDP SERIES - SUBMERSIBLE PUMPS FOR PROFESSIONAL DRAINAGE 50 HZ



FDP Series (Franklin Dewatering Professional)

Submersible pumps for clear and turbid water drainage

Submersible electric pumps in cast iron and stainless steel, suitable for draining clear and turbid waters. They can be used as ready-to-use portable pumps both for construction site use, basement wells, and for fixed installations with control panel.

- Open impeller
- 40FDP: 1 - 1.8 kW, up to 25.2 m³/h, up to 32 m
- 50FDP Series: 1.4 - 2.2 kW, up to 54 m³/h, up to 18.5 m
- 70/80FDP Series: 2.2 - 4.1 kW, up to 100.8 m³/h, up to 23.3 m
- 100FDP Series: 5.5 - 8.1 kW, up to 180 m³/h, up to 45 m
- 100/150 FDP-LH/HH Series: 11 - 15 kW, up to 252 m³/h, up to 62 m
- 150FDP Series: 22 kW, up to 324 m³/h, up to 35 m



APPLICATIONS



Drainage and dewatering



Rainwater Recovery



Construction site drainage and dewatering



Mining, Quarrying drainage and dewatering



Emergency flood water drainage

UTILITY PUMP

5-MSP UTILITY PUMP



The 5-Series is one of the most compact utility pumps on the market, ideal for light commercial and residential applications where water removal, transfer, or circulation is required.

- Corrosion and rust-resistant materials
- Epoxy-coated cast aluminum pump housing gives strength and high heat dissipation for both consumer and professional use.
- Rated for continuous duty which allow a wide range of applications
- Compact design and light weight make this pump truly portable
- Environmentally friendly, energy efficient and oil free 180 W PSC motor, Max. flow: 88 l/min, Max. head: up to 5.8 m
- FKM triple-lip seal
- Upper and lower ball bearings for long life
- 1" BSPT discharge
- Garden hose adapter 3/4" NPT and garden rubber holder adapter 20 mm
- Removable inlet screen allows easy cleaning without tools
- Maximum solids size: 3 mm
- Standard power cable: 10 m with Schuko plug
- Maximum liquid temperature: 49 °C



APPLICATIONS



pumping of clear non-loaded fluids



Extraction of water from ponds, streams or pits and for rainwater collection

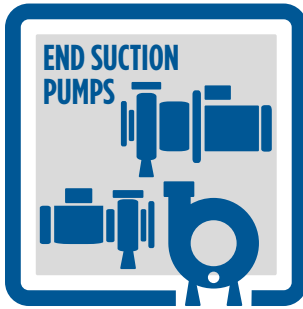

END SUCTION CENTRIFUGAL PUMPS

Cast iron pumps according to EN 733



The FN series is ideal in terms of quality and efficiency. The End suction centrifugal electric pumps are designed to pump clean liquids, without abrasives and suspended solids, non-explosive environments.

Motors

The motors are available according to the highest standard of efficiency. The product is available in numerous configurations in terms of compatibility of pumped liquids.

Impeller with cataphoresis coating

for corrosion resistance

Standard Reference

ErP 547/2012 (MEI > 0.4)
640/2009 (Motors efficiency class IE3
UNI EN 733 (DIN 24255)

High Temperature liquids

Maximum liquid temperature:
up to 90 °C for domestic use
up to 120 °C for industrial use

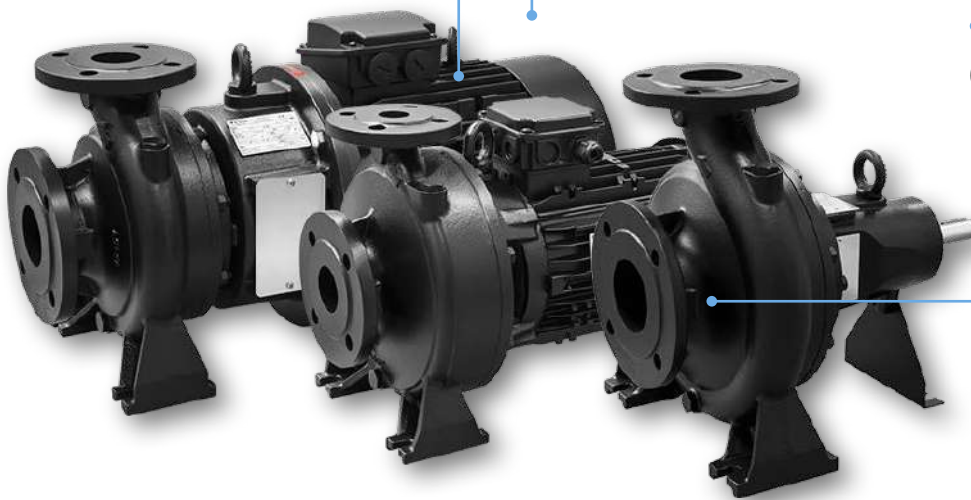

APPLICATIONS



Water Distribution, Water treatment, Water supply



Irrigation, Water treatment



Industrial plants

OPTIONS

- FNEM: version with motor, coupling and base (on request)

FNE - BARE SHAFT PUMPS

FEATURES & BENEFITS

- Version without motor, suitable to be coupled with a Standard electric motor.
- Pump body / Mechanical seal housing / Motor bracket: Cast-iron GG20 with anti-corrosive coating
- Suction/delivery ports: according to standard EN1092-2
- Impeller: Cast-iron GG20 with cataphoresis coating
- Pump shaft: Stainless steel AISI 304
- Mechanical seal Type PO: Carbon / Ceramic / NBR

MOTOR SPECIFICATION

- Models: FNE 32-40-50-65-80
- Flow: up to 240 m³/h at 50 Hz
- Head: up to 100 m at 50 Hz



END SUCTION CENTRIFUGAL PUMPS

FNC - EXTENDED SHAFT PUMPS



FEATURES & BENEFITS

- Close-coupled pumps with extended shaft motor
- Models: FNC 32-40-50-65-80
- Pump body / Mechanical seal housing / Motor bracket: Cast-iron GG20 with anti-corrosive coating
- Suction/delivery ports: according to Standard EN1092-2
- Impeller: Cast-iron GG20 with cataphoresis coating
- Pump shaft: Stainless Steel AISI 304
- Mechanical seal Type P0: Carbon / Ceramic / NBR
- Flow: up to 180 m³/h at 50 Hz
- Head: up to 90 m at 50 Hz
- Maximum working pressure: PN10
- Asynchronous squirrel cage-type motor

MOTOR SPECIFICATION

- External ventilation
- Incorporated motor protection and capacitor integrated for single-phase motors
- Motor protection for 3- motors must be installed by the customer (equipment compliant with current standards recommended)
- Efficiency class: IE3
- Protection IP54, Insulation class: F



FNS - STUB SHAFT PUMPS



FEATURES & BENEFITS

- Models: FNS 32-40-50-65-80
- Rigid-coupled with a bracket, an adapter and a rigid coupling keyed to the Standard motor shaft extension
- Pump body / Mechanical seal housing / Motor bracket: Cast-iron GG20 with anti-corrosive coating
- Suction/delivery ports: according to Standard EN1092-2
- Impeller: Cast-iron GG20 with cataphoresis coating
- Pump shaft: Stainless Steel AISI 304
- Mechanical seal Type P0: Carbon / Ceramic / NBR
- Flow: up to 240 m³/h at 50 Hz
- Head: up to 100 m at 50 Hz
- Maximum working pressure: PN10

MOTOR SPECIFICATION

- Asynchronous squirrel cage-type motor
- External ventilation
- Motor protection for 3- motors must be installed by the customer (equipment compliant with current standards recommended)
- Efficiency class: IE3
- Protection IP55, Insulation class: F
- Service class: S1





CONSTANT PRESSURE SYSTEM

SUBDRIVE CONNECT

Constant-pressure system through variable speed control of submersible pumps

- Optimization of system performance and water pressure supply
- Built-in diagnostics and protection
- Easy commissioning by plug and play system
- Input Voltage: 230V AC
- Wi-Fi connection for use with the FE Connect mobile application for advanced settings and monitoring
- Constant water pressure with a wide range of settings (0.5 to 9.5 bar)
- User-defined motor frequency range and set-up
- Easy-to-read LCD display for system pressure and fault identification
- Built-in duplex alternator for dual drive operation
- Proven components for long-term reliability
- Backwards compatibility and easy installation
- Single-phase 3-wire motor operation (60 Hz)
- Advanced motor soft-start feature increases motor life
- CE, cULus and UL approved

OPTIONS

- Moisture Sensor – Weet floor identification
- 4-20 mA analog pressure transducer – 6, 10, 16 bar
- Outdoor rated cable kit for analog pressure transducer
- Communication cable kit for built-in duplex alternator
- Replacement Kit for Input and Display Board
- Input and Output Filter
- Lightning Arrestor
- Fan Replacement Kit
- Standard SubDrive Pressure Switch
- Spare part kits for electronic controller and motor



VARIABLE FREQUENCY DRIVES (VFD)

First class performance and control with Variable Frequency Drives for submersible pumping systems, water booster sets and HVAC systems with circulating pumps

FEATURES & BENEFITS

- Energy saving due to variable speed control
- Soft start and soft stop
- Extended system life and reliability
- Simplified installation on motor or wall
- Easy and fast commissioning due to initial configuration wizard
- High thermal and mechanical performance thanks to aluminum case and independent ventilation
- Advanced user experience with App FE Connect Drive-Tech

DRIVE-TECH

- Reduced energy consumption / cost saving
- Longer life of pumping system
- Greater reliability of the complete unit
- Compact design, compatible with most pumps on the market
- Steady operation conditions in terms of pressure, flow and temperature.
- Motor protection and monitoring:
 - Overload and dry running protection
 - Integrated soft start and soft stop functions, extending the life of the system and reducing peak variation
 - Input current and supply voltage
 - Recording running hours and login errors and alarms reported by the system
 - Control of a second or third pump at constant speed DOL
 - Connection to other Drive-Tech to get combined operation
- Enclosure is entirely made of die-cast aluminum and is very

sturdy, lightweight, easy to cool down and very compact in size.

- Top class protection IP66/65 enclosure class (installations in humid and dusty places possible)
- Easy operation due to display placed on top and buzzer in case of alarm
- Optimized for submersible permanent magnet motor feeding



CERUS X-DRIVE

This frequency converter is a fully featured, all-inclusive, reliable drive solution for a wide range of different applications. The Cerus X-Drive combines complex design and feature set, necessary for the most demanding applications in pump, HVAC and industrial markets, with the ease of an economic user-friendly variable speed controller.

- Wide performance range up to 250 kW
- Application-specific pre-sets for quick and easy startups
- State of the art motor and pump protection features
- Multi segment IP66 digital removable display
- Bluetooth connectivity (VFD type Drive-Tech MINI: up to 4 kW)
- Built-in DC choke for applications of 37 kW and above
- Compact form-factor allows installation in smaller panel
- CE and UL approved

EASY INSTALLATION & SUPPORT

- Intuitive start-up experience with application-specific parameter pre-sets
- Setup/commissioning through user-friendly digital display or Mobile App
- Copy-paste parameter setup between two drives through digital display data storage



VARIABLE FREQUENCY DRIVES (VFD)

DRIVE-TECH MINI

- Remote control via Bluetooth and Mobile App
- Top class protection IP66/65 enclosure class (installations in humid and dusty places possible)
- Multiple control modes
- Built-in protection against dry run
- EMC compatibility for home environment:
- Advanced motor controls:
- Suitable to use with permanent magnet motors
- Analog inputs and outputs



DRIVE-TECH MINI SOLAR

- MPPT control maximizes efficiency of input power
- Powered by DC solar array
- Built in diagnostics and protection features
- Soft-start feature prevents water hammer and increases system life
- Control of AC induction and permanent magnet synchronous motors
- Robust IP55 minimizes impact of wildlife, insects, dust and weather



DRIVE-TECH COMPACT

Compact, robust, and functional Variable frequency drive up to 22 kW

- State of the art motor and pump protection features
- Factory-featured with Bluetooth 4.0 connectivity
- Remote control, commissioning and support through Drive-Tech Connect Mobile App
- OLED digital user display
- Built-in dV/dt filtering for best motor protection
- Robust IP66 enclosure rating for harsh environments
- DC solar supply
- Direct wall mount and surface pump installation
- CE approved



EASY INSTALLATION / REMOTE CONTROL / TROUBLESHOOTING / SUPPORT

- Real-time monitoring through FE Drive-Tech Connect Mobile App
- Remote Support, commissioning, and support by Franklin Electric Service Team
- Fully accessible everywhere and any time (Cellular mobile network connection required)

PROTECTION / CONTROL

SUBMONITOR MOTOR PROTECTION



State-of-the-art 3-phase pump protection to sense overheating straight from the motor windings

- Protection of 3-phase pumps with ratings between 3 and 200 hp, for motors with service factor amp ratings between 3 and 359 Amps
- Current, voltage and motor temperature are monitored using three integrated current transformers.
- Input Voltage: 190 - 600 VAC
- Digital display provides current and voltage readings for all three legs at the same time, and allows the user to set up the SubMonitor quickly and easily. Fault messages are easy to understand.
- Quick Setup guide for monitoring (simply entering line frequency (Hz), line voltage (Volt), and Motor Service Factor Amp rating)
- Monitors - Under/Overload; Under/Overtension; Current Unbalance; Overheated Motor (Subtrol Equipped); False Start (Chattering); Phase Reversal
- No need to make add. turns around the CT or add external CTs
- Password Protection Option
- DIN Rail Mounting Option
- Stores fault, setting changes, and pump run-time can be accessed through the display
- Lightning protection included in the Premium Package
- Detachable NEMA 3R display unit can be mounted on panel door
- UL 508 listed



SUBSTART SC



Single-phase Submersible Motor Starter

- The SubStartSC range covers all PSC motors from 0.25 kW to 2.2 kW for all voltages.
- Ergonomic design
- Easy installation / Wall mounting
- IP54 protection
- Voltage Tolerance: 220 - 240 V; -6 / +10 %; 50 Hz single phase
- Reliable protection features
- Attention to detail – every aspect engineered for the application
- The device is 100% compatible with the motor characteristics
- Integrated thermal circuit breaker
- High-quality motor run capacitor for long-life endurance
- Terminal board suitable for ease of reliable connections



SUBSTART 3P



3-phase Submersible Motor Starter

- The SubStart3P® range covers all 3 phase motors from 0.37 kW to 7.5 kW.
- Ergonomic design
- Easy installation / Wall mounting
- IP54 protection
- Voltage Tolerance: 380 V -10 % / 415 V +6%
- Attention to detail – every aspect engineered for the application
- The device is 100% compatible with the motor characteristics
- Circuit breaker integrated thermal and magnetic overload protection
- Powered auxiliary contactor for use with external switches



PROTECTION / CONTROL

SUBTRONIC SC



Single-phase Submersible Motor Protection for PSC motors from 0.25 - 2.2 kW

- The SubTronicSC range covers all PSC motors from 0.25 kW to 2.2 kW for all voltages.
 - Ergonomic design
 - Easy installation / Wall mounting
 - IP54 protection
 - Voltage: 220 - 240 V; $\pm 10\%$; 50 Hz single phase
 - Attention to detail – every aspect engineered for the application
 - The device is 100 % compatible with the motor characteristics
- Intelligent Protection features:
 - Dry-run detection
 - Dry-run auto-reset
 - Over & Under voltage
 - Over current protection
 - Faulty Start Protection
 - Rapid Cycle Protection



SUBTRONIC 3P



3-phase submersible motor Protection for 3~ motors from 0.37 - 7.5 kW

- Wide range of operation: Compatibility with motor design allows a wide range of operation resulting in minimized nuisance tripping.
- Ergonomic design
- Easy installation / Wall mounting
- IP54 protection
- Voltage Tolerance: 380 V -10 % / 415 V +6 %
- Reliable protection, Sophisticated system management and peace of mind
- Attention to detail – every aspect engineered for the application
- Intelligent Protection features:
 - Dry-run detection
 - Dry-run auto-reset
 - Over & Under voltage
 - Over current protection
 - Rapid Cycle Protection



PRESS-TECH / PRESS-TECH S



Pump protection and control

- Fixed Starting pressure
- Power voltage:
 - Press-Tech: 1 x 115 Vac - 230 Vac $\pm 10\%$
 - Press-Tech S: 1 x 230 Vac $\pm 10\%$
- Frequencies: 50 Hz / 60 Hz
- IP65 Protection
- Maximum working pressure: 12 bar
- Maximum working temperature: 65 °C



PROTECTION / CONTROL

COV-BOX M SERIES

Control box for the price-competitive protection from overload

- Ratings: 0.37 kW (0.5 HP) up to 2.2 kW (3.0 HP)
- IP50 Protection
- Run capacitor
- Thermal overload circuit brake with manual reset
- Connection terminal board
- Wiring diagram
- Switch ON-OFF



QC-AV/E SERIES

Single-phase control box for the overall protection / starting assistance

- Ratings: 0.37 kW (0.5 HP) up to 2.2 kW (3.0 HP)
- IP50 Protection
- Electronic start capacitor / disconnecting run capacitor
- Starting assistance under low voltage or voltage drops
- Thermal overload circuit brake with manual reset
- Terminal board connections
- Wiring diagram



QC-AV SERIES

Single-phase control box for the overall protection / starting assistance / voltmetric relay

- Ratings: 3.0 kW (4.0 HP) up to 4.0 kW (5.5 HP)
- IP50 Protection
- Start electrolytic capacitor / disconnecting relay / potential relay / run capacitor
- Thermal overload circuit brake with manual reset
- Connection terminal board
- Wiring diagram
- Pilot lamp / Switch ON-OFF



COV-BOX T SERIES

Three-phase control box for the overall protection

- Ratings: 0.37 kW (0.50 HP) up to 7.5 kW (10 HP)
- Metal zinc coated plate for grounding
- General isolating switch with locking door
- Line counter with thermal relay, adjustable scale and internal set
- Protection cutout (fuses) for motor and auxiliary circuits
- Green lamp indicating motor running
- Floating switch connection (optional) on switchboard
- Wiring diagram
- Pilot lamp / Switch ON-OFF



ACCESSORIES

CORROSION PROTECTION 4"

- For use in more aggressive media
- Mounting on the bottom of the motors
- Material: GG 25

System of operation: Wells with extremely high levels of chlorides and other elements combined with high temperatures will attack almost any type of metal, including Stainless-steel. When in contact with a more noble metal, the less noble metal becomes the anode of a galvanic cell. Oxidation occurs at the anode. It slowly dissolves (sacrificial anode), leaving the more noble metal unaffected. The result is a longer service life of the motor/pump unit in more aggressive media.



4000N



6500N



COOLING SLEEVE FOR SUBMERSIBLE MOTOR PUMPS 4"/6"/8"/10"/12"

- The cooling jacket is the ideal solution for vertical and horizontal installations of submersible motor pumps in rainwater cisterns and deep wells to ensure the cooling flow along the motor
- It guarantees sufficient cooling of the motor.
- It is supplied with a filter that prevents leaves or small stones from being sucked in.

Components cooling sleeve kit:

- Cooling sleeve tube (Stainless-steel)
- Pump sealing ring (EPDM) with drinking water approval
- Motor spacer
- Pipe clamps
- Filter strainer (accessories)
- Console (accessory for horizontal mounting)



MOTOR/PUMP-COUPLINGS

- Line of motor-pump couplings for maximum customer convenience for matching the Franklin motor to a variety of pump shafts.
- Couplings are designed to transmit the pump thrust to the motor in order to provide maximum benefits from the Franklin internal thrust bearing construction.
- Hardened Stainless-steel spacer discs in the 4" and 6" couplings assure positive bearing between motor and pump shafts and assure full support for downward thrust created by the pump. 8" couplings DO NOT contain hardened spacer discs, since the motor shaft itself is hardened.
- NEMA standard measuring on motor shaft
- Material: 304SS / 316SS



DC DISCONNECT

- To disconnect the drive even under load safely from the solar generator, Franklin Electric offers suitable DC disconnect switches for different power ratings.



ACCESSORIES

DRIVE-TECH MINI ACCESSORY KIT

- Cable with plug 230V
- Screws and connectors
- Wall mounting plate



DOUBLE PLUG LEAD FOR 4" TERMINATION KIT

Required for use of lead termination kits. Connection between termination kit and 4" motor.

- Max. current: 18 Ampere in air at max. 50 °C ambient temperature
- Max. current: 23 Ampere submersed in water at max. 30 °C ambient temperature
- Max. Voltage: 750 V AC
- PSC / 2-wire / 3-wire motors and 3 - motors
- with or without strain relief
- KTW approval



MOTOR FILLING LIQUID



Description	FES92	FES91	FES93
5 l motor filling liquid FES92			

motor type	required motor filling
4" encapsulated Standard / PM motor	FES93
6" encapsulated Standard / PM motor	FES91
6" encapsulated High Temp 90 °C motor	FES92

motor type	required motor filling
8" encapsulated Standard motor	FES91
8" encapsulated High Temp 75 °C motor	FES92
6"/8"/10"/12" rewindable Standard / PM motor	FES93

FLOAT SWITCH

- A float switch is a device used to detect the level of liquid within a tank.
- Required part for some High Efficiency Solar Systems



ACCESSORIES

FLOW PADDLE SWITCH

- The flow switch utilizes the force of liquid flow to propel its paddle and to detect the incoming flow or movement of the existing liquid in the pipe.
- Required part for some High Efficiency Solar Systems



INLINE FLOW SWITCH

- The Inline Flow Switch operates magnetically. The piston within the switch body should be a free fit and spring back to its off position as soon as flow stops.



MOTOR FILLING TOOL KIT

- This kit contains all necessary tools to check and replenish Franklin Electric submersible motors with FES91, FES92 or FES93 filling liquid.



PERMANENT STAR PLUG 6"

- For specific applications it is necessary to permanently run a star-delta submersible motor in star connection. This may be achieved by using the *PERMANENT-STAR-PLUG*.
- This connector short-circuits all three pins in one of the two motor sockets and is designed to replace one lead.



PRESSURE SWITCH SUBDRIVE - CONSTANT-PRESSURE CONTROLLER

1. The pressure switch continuously monitors the pressure in the water supply system and feeds the information to the SubDrive controller.
2. The factory setting of the desired pressure is 3.4 bar (can be changed).



ACCESSORIES

PT100 SENSOR FOR ENCAPSULATED MOTORS (STANDARD / PM)

- The PT100 is a precision platinum wire resistor that is specified occasionally as a temperature input for process control equipment. A jacketed control lead must be run from the PT100 lead to the above-ground equipment.
- To install the PT100 sensor bolt, remove the top end bell bolt that is opposite of the lead and replace it with the PT100 screw. Tighten the sensor bolt to the torque values shown below.

Standard motors:



HighTemp motors:



PT100 SENSOR FOR REWINDABLE MOTORS

- Continuous monitoring of the temperature of the filling liquid above the winding head
- Fitted into the upper end bell flange, all 6"/8"/10"/12" Std. rewindable motors are prepared for the PT100 installation



PUMP CONNECTION SCREW KITS

- Pump connection screw kits for 6" / 8" encapsulated motors and 8"/10"/12" rewindable motors

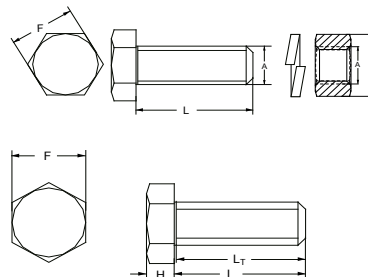

ACCESSORIES

SPLICING KIT 1.5 - 95 MM²

- This kit allows the connection of a motor short cable with an extension cable in the range up to 95 mm².
- Suitable for all common cable materials
- Long durability
- High electrical insulation values and mechanical strength
- Quick and easy assembly
- Components: Transparent plastic shell, Ready-to-mix cast resin, insulation tape, assembly instruction



SURGE ARRESTORS

- Surge arresters protect the submersible motor from a variety of commonly occurring high voltage spikes, which can permanently damage the insulation system and thus cause motor winding failures.
- The surge arresters are not suitable for discharging direct lightning strikes



TERMINATION KIT FOR 4" MOTORS

This proven, sturdy solution is your choice of cable splicing in temporary pump applications or when reusing drop cable. The flexibility and safety it provides for under field service conditions makes it the preferred choice over conventional, not breakable splicing kits.

- For PSC / 2-wire / 3-wire motors and 3- motors
- Max. current 18 Ampere in air at max. 50 °C ambient temperature
- Max. current 23 Ampere submersed in water at max. 30 °C ambient temperature
- Max. voltage: 750 V
- Optional strain relief



ACCESSORIES

REVISION CHANGE NOTICE

Rev. No.	Changes	Page
01	New 4" encapsulated Super Stainless motor added	9-10
	Product description VS 4-6-8 / VSC 8-10-12 adjusted	22-23
	Product description 5" close-coupled pumps / VL pump adjusted	24-25
	10" High Efficiency System with rewindable motor added	25
	6" High Efficiency System with rewindable motor deleted	28
	10" High Efficiency System with rewindable motor added	29
02	Picture 4" double plug lead	49
	6" HighTemp 90 description adjusted	13
	Product description VS 4-6-8 / VSC 8-10-12 adjusted	22-23
03	Portfolio description adjusted	5
	4" motor, High thrust version added	9
	4" /6" PM motors: voltage tolerance added, installation orientation adjusted	11,13
	6" High Temp 90 °C motor, description adjusted	13
	8"/10" rewindable PM motors added	18, 20
	10" High Efficiency System, motor ranges adjusted	31
	EV series, new features updated	Cover, 4, 30, 31
	VS 6"-8" series, description updated	22, 23,24
	VN series, "discharge outlet" updated	26
	Booster sets, "versions" updated	36
	EH-EHsp series, description updated	38
	Drainage pumps, description updated	40, 41
	FNEM option added	42
Corrosion protection 4" motors, description adjusted	50	
04	Material description for WW motors added	all
	WW logo for 6" oilfilled motors added	15
	Standard lead lengths for 4" oilfilled motors added	11
	Storage temperature for 4" motors added	all
05	8" rewindable PM motor range adjusted to 75 - 130 kW	18, 27, 30
06	ACS drinking water approval added for submersible Franklin Electric motors	8
	ACS/ICIM drinking water approvals added for submersible VS 6"/8" pumps	22
	ICIM drinking water approval added for close-coupled VN 5" pumps	25
	ICIM drinking water approval added for Vertical multistage EV pumps	32
07	Table frequency drives deleted, CERUS X-DRIVE drive added, DrivE-Tech COMPACT added	45,46
	10" 150kW PM Motor hinzugefügt in der Motorsektion und bei 10" HES Systemen	20 / 31
	add UBA Logo for FE Submersible Motors	8
08	DrivE-Tech MINI accessory kit added	55
	video links added	all
09	Sewage and drainage pumps added	42-44
10	Submersible pump series VSI added	cover, 4, 24
	Heat pump motor added	10
	Built-in PTC temperature sensor deleted	12, 56
	Motor efficiency class adjusted	33-37
	Utility pump 5-MSP added	44
	EM Dtm pump deleted	35
	EHsp pump deleted	37



Franklin Electric

Franklin Electric Europa GmbH
Rudolf-Diesel-Str. 20 - 54516 Wittlich
GERMANY
Phone: +49 (0) 6571 - 105-0
Fax: +49 (0) 6571 - 105-510
Email: info@franklin-electric.de

Franklin Electric S.r.l.
Via Asolo, 7 - 36031 Dueville (Vicenza)
ITALY
Phone: +39 0444 361114
Fax: +39 0444 365247
Email: sales.it@fele.com



10000005490 EN REV.10_07-2023



franklinwater.eu

Single member - Company subject to the control and coordination of Franklin Electric Co., Inc.
Franklin Electric reserves the right to amend specification without prior notice.